

### Grounding/Bonding & Meter Socket

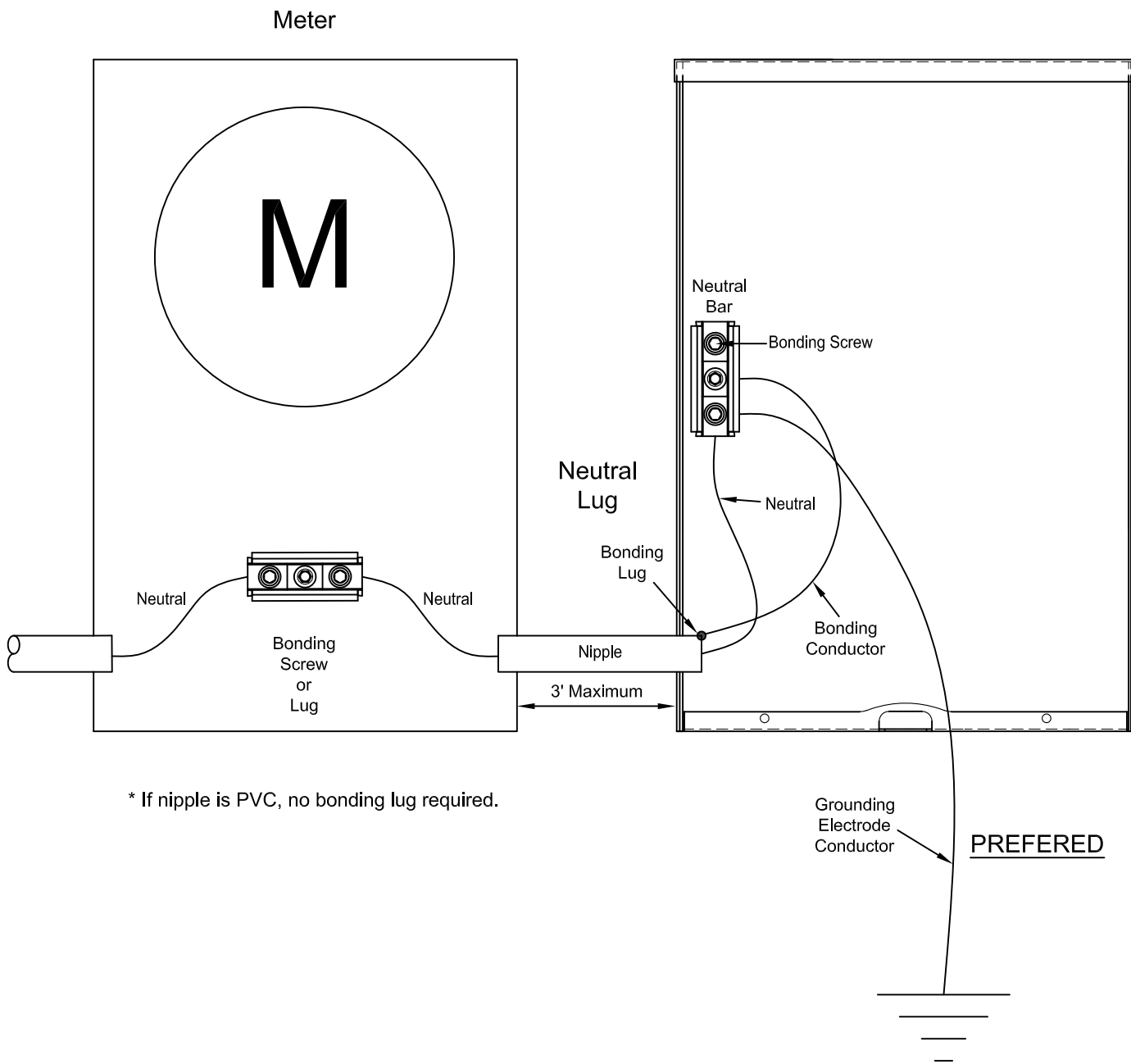

\* If nipple is PVC, no bonding lug required.

NOTES

- (1) In some cases such as switchgear, meter packs, pedestals, temp services, etc. the drawings may not apply due to how things are manufactured. These would fit for most single meter, self-contained services.

### Grounding/Bonding & Meter Socket

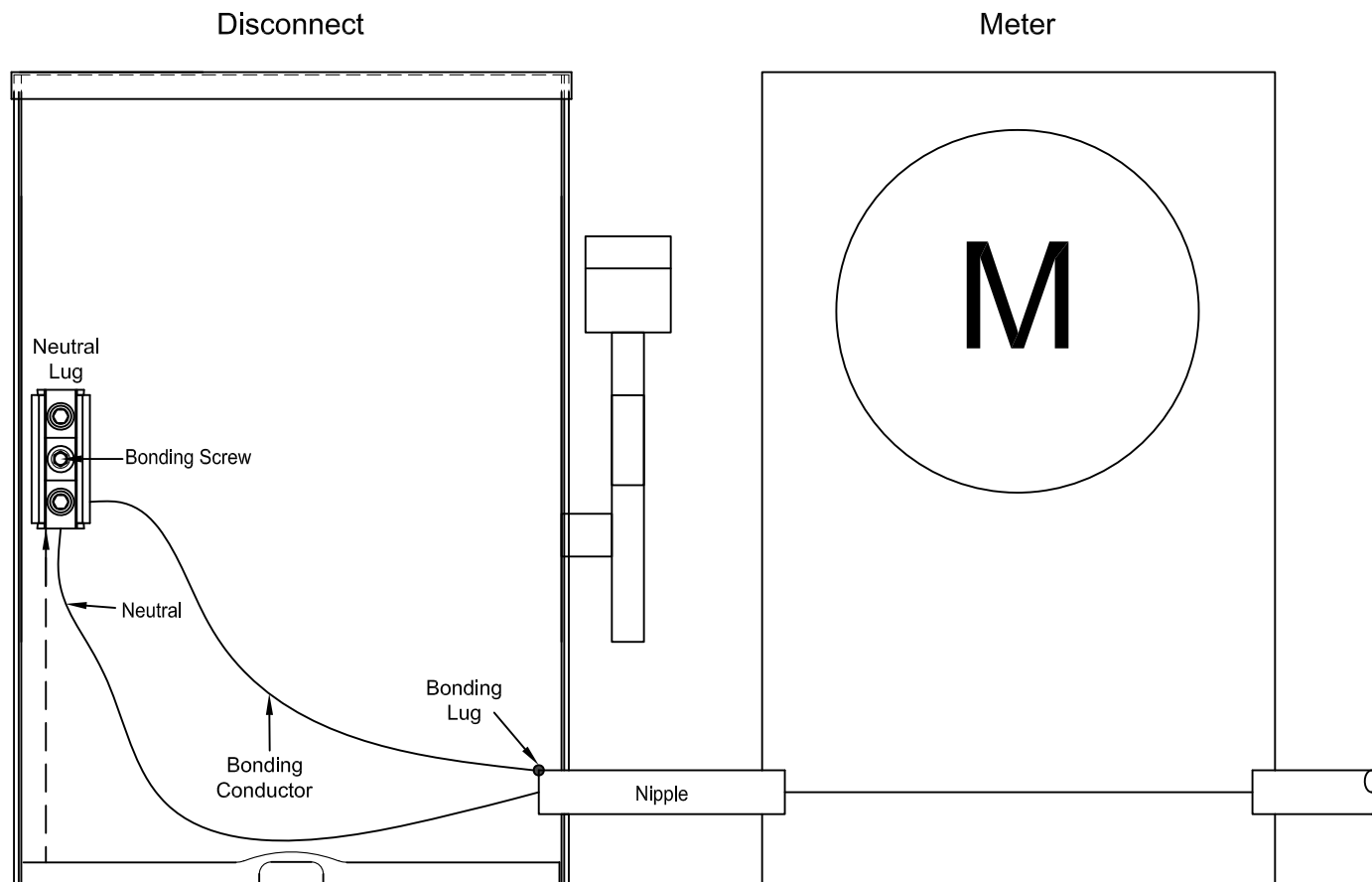

\* If nipple is PVC, no bonding lug required.

REC Bonding - Since PNM put the isolation switch ahead of the REC Meter Bonding is done at the Isolation Switch if needed, no the socket

NOTES

- (1) In some cases such as switchgear, meter packs, pedestals, temp services, etc. the drawings may not apply due to how things are manufactured. These would fit for most single meter, self-contained services.

### Grounding/Bonding & Meter Socket

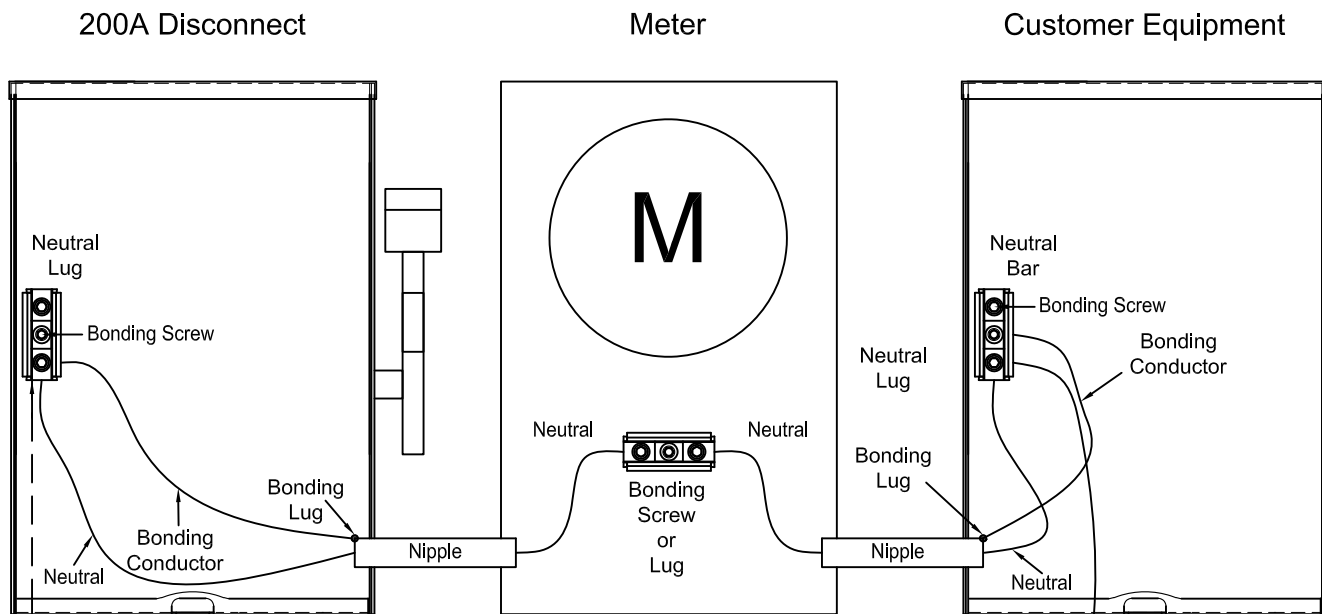

\* If nipple is PVC, no bonding lug required.

OPTIONAL

PREFERRED

#### NOTES

- (1) In some cases such as switchgear, meter packs, pedestals, temp services, etc. the drawings may not apply due to how things are manufactured. These would fit for most single meter, self-contained services.

APPROVED

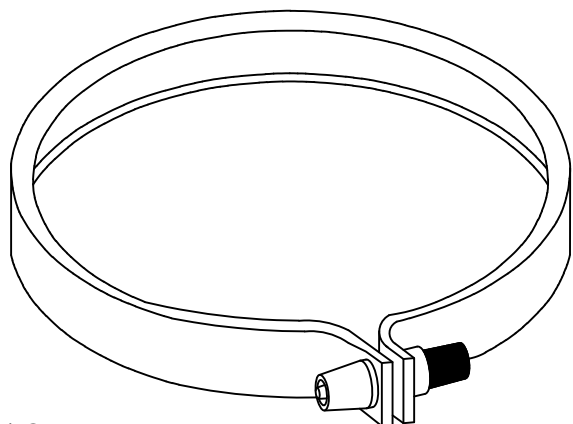

(A) Screw Barrel - Type Ring

APPROVED

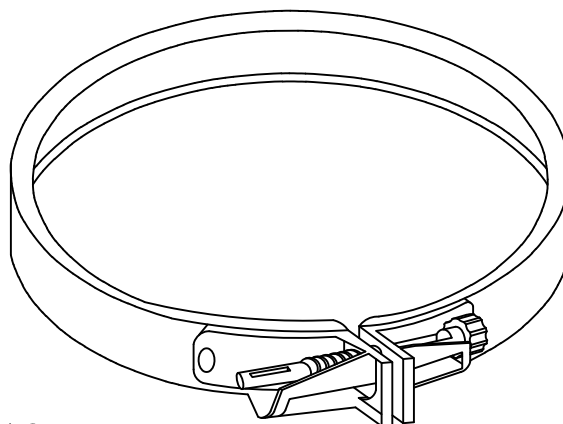

(B) Screw - Type Ring

**MAINTENANCE  
ONLY**

DISAPPROVED

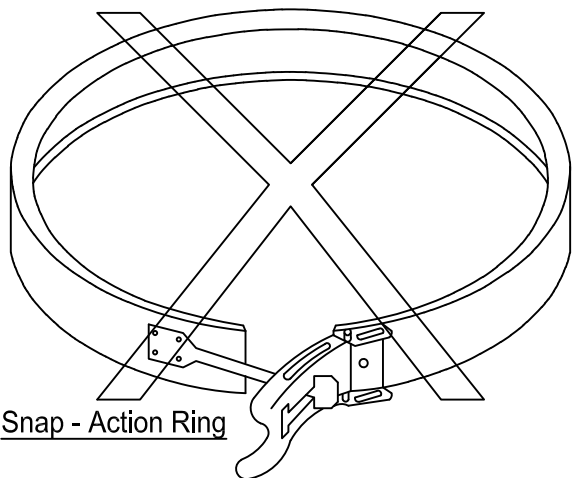

(C) Snap - Action Ring

DISAPPROVED

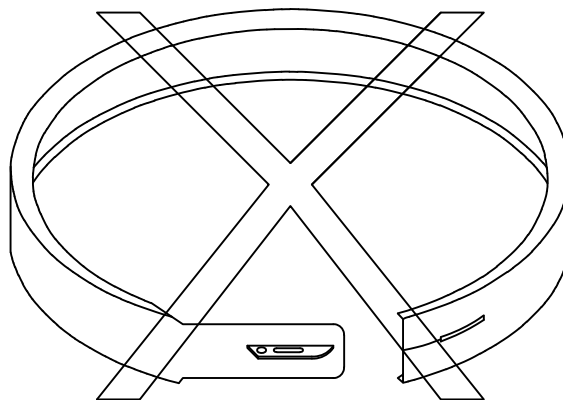

(D) Slip - Lock Ring

**NOTES**

- (1) Type A socket ring 7000-480450 is approved for use on PNM's system.
- (2) Type C has been disapproved due to installation problems, effective 08/01/11. Type D has been disapproved due to installation problems, effective 01/01/88.

Approved Equipment		
Manufacturer	Item	Mtg Part #
Brooks	Socket Ring	10-9090
DeWalch	Socket Ring	2221-1

For ease of checking service without interruption, PNM will no longer allow ring meter sockets as of 12/01/2013.

APPROVED

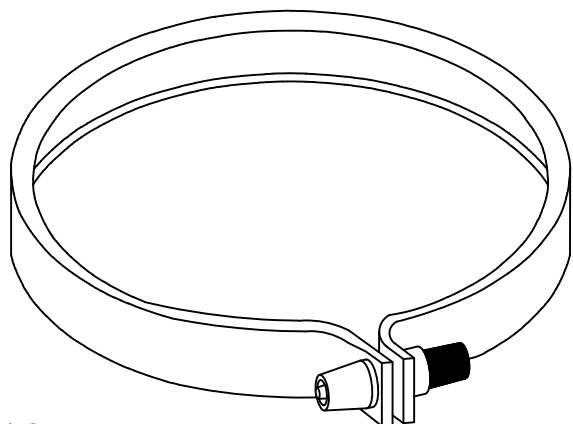

(A) Screw Barrel - Type Ring

APPROVED

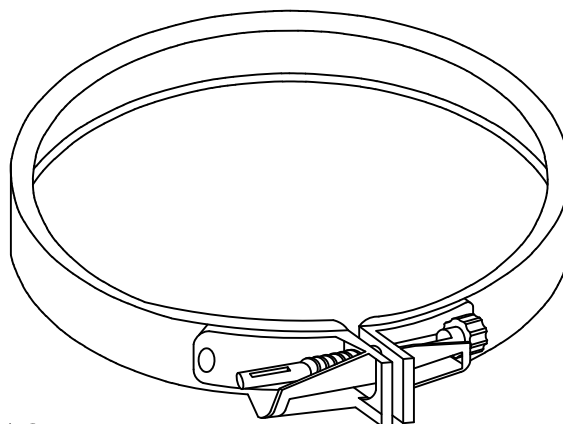

(B) Screw - Type Ring

**MAINTENANCE  
ONLY**

DISAPPROVED

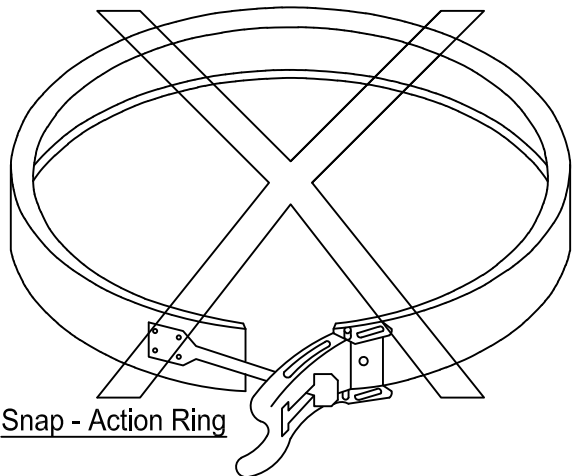

(C) Snap - Action Ring

DISAPPROVED

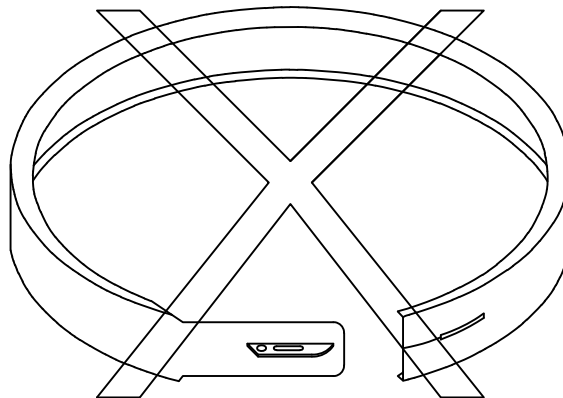

(D) Slip - Lock Ring

**NOTES**

- (1) Type A socket ring 7000-480450 is approved for use on PNM's system.
- (2) Type C has been disapproved due to installation problems, effective 08/01/11. Type D has been disapproved due to installation problems, effective 01/01/88.

Approved Equipment		
Manufacturer	Item	Mtg Part #
Brooks	Socket Ring	10-9090
DeWalch	Socket Ring	2221-1

For ease of checking service without interruption, PNM will no longer allow ring meter sockets as of 12/01/2013.

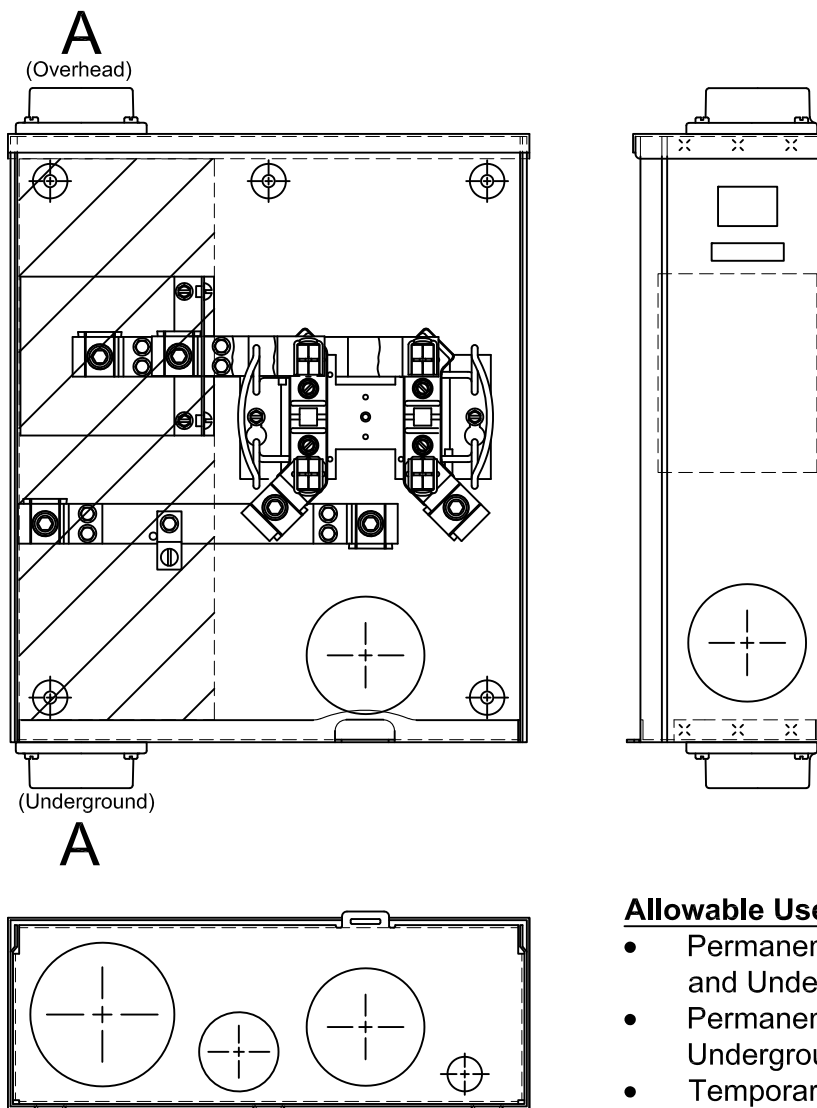

**Allowable Uses**

- Permanent 120/240 Overhead and Underground Services
- Permanent Customer Owned Underground Services
- Temporary Overhead and Underground Service

**NOTES**

- (1) Socket to be Underwriters Laboratory (UL) listed.
- (2) Connections for terminating service conductors shall be the lay-in type.
- (3) Service conduit to enter at point "A"
- (4) No load conduits or load conductors in shaded area from front to back.
- (5) PNM will make line terminations on underground permanent residential services only.
- (6) 125A is only applicable for manufactured, mobile homes, temporary overhead and underground service and replacing existing 100A or less meter socket.
- (7) Meter shall be 4' - 5' 6" from finished grade.
- (8) If load is >320A, must use use MS-3-7.0.
- (9) PNM does not permit a trough ahead of meter socket.
- (10) Metering and instrument cabinets shall not be used to house Customer-owned equipment, such as distribution panels or other equipment, nor used as a junction box/trough for the distribution of circuits.
- (11) Customer building numbers must be permanently painted on proper meter panels.

**REFERENCES**

- (1) See DS-4-5.0 Underground Service Entrance System
- (2) See DM-4-11.0 Maximum Available Fault Current
- (3) See MS-3-7.0 Over 320A 240V Single-Phase Meter

Approved Equipment		
Manufacturer	Item	Mfg Part #
Eaton	125A UG Ringless Socket	UTRS101BE
Eaton	125A UG Ringless Socket	UTRS101CE
Eaton	200A OH/UG Ringless Socket	UTRS213CE
Eaton	200A OH/UG Ringless Socket	U92197CCCPLCH
Milbank	200A OH Ringless Socket	U7021-RL-TG
Milbank	200A UG Ringless Socket	U1980-O
Milbank	200A UG Ringless Socket	U4413-O
Milbank	200A UG Ringless Socket	U3850-O-TG
Milbank	200A OH/UG Ringless Socket	U8173-XL-KK-BLG
Siemens	200A UG Ringless Socket	UAS877-PG
Square D	200A OH/UG Ringless Socket	UTRS101B
Square D	200A OH/UG Ringless Socket	U92197CCCPL
Square D	100A OH/UG Ringless Socket	RC1624M100S
Square D	100A OH/UG Ringless Socket	RC816F100CH

For ease of checking service without interruption, PNM will no longer allow ring meter sockets as of 12/01/2013.

120/240V 100/200A Permanent  
Overhead or Underground Single-Phase Meter Socket

MS-2-2.0

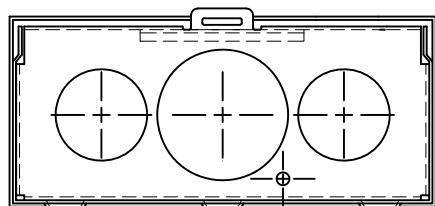
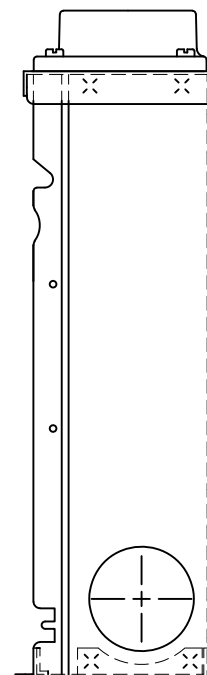
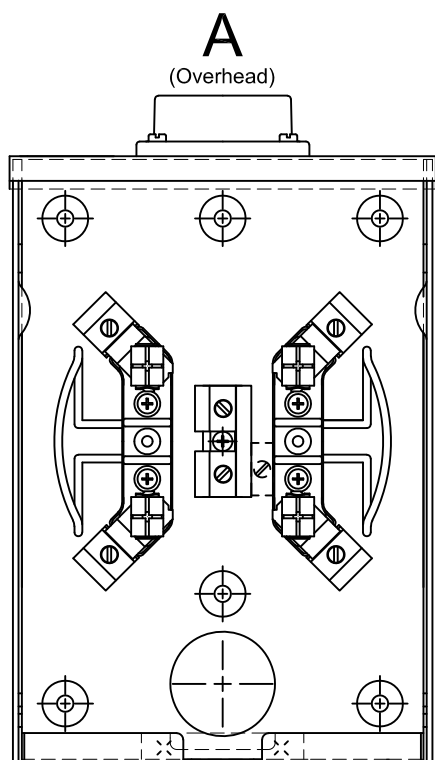

**Allowable Uses**

- Manufactured/Mobile Homes
- Replacing existing 100A or less meter socket
- Non-critical commercial application

**NOTES**

- (1) Socket to be Underwriters Laboratory (UL) listed.
- (2) Connections for terminating service conductors shall be the lay-in type.
- (3) Service conduit to enter at point "A"
- (4) Meter shall be 4' - 5' 6" from finished grade.
- (5) Commercial application for non-critical loads, i.e. sprinkler control and gates. PNM will allow socket without bypass handle.
- (6) PNM does not permit a trough ahead of meter socket.
- (7) Metering and instrument cabinets shall not be used to house Customer-owned equipment, such as distribution panels or other equipment, nor used as a junction box/trough for the distribution of circuits.
- (8) Customer building numbers must be permanently painted on proper meter panels.

**REFERENCES**

- (1) See DS-4-6.0 120/240V Underground Service Pole
- (2) See DS-4-8.0 Overhead Permanent/Temporary Single-Phase or Temporary Three-Phase Service Pole
- (3) See DS-4-9.0 Underground Residential Customer-Owned Service
- (4) See DM-4-11.0 Maximum Available Fault Current

Approved Equipment		
Manufacturer	Item	Mfg Part #
Durham	100A OH/UG Ringless Socket	UTRS101B
Eaton	125A OH Ringless Socket	MBT48B125BTS
Eaton	125A OH Ringless Socket	UTRS101(*E
Eaton	125A OH Ringless Socket	1MP***
Milbank	125A OH/UG Ringless Socket	U7487-RL-TG
Milbank	125A OH/UG Ringless Socket	U7487-RL-TG-KK
Milbank	125A OH/UG Ringless Socket	U5101-XL-75
Square D	125A OH Ringless Socket	RC8165100CH

\* Varies depending on hub size.

For ease of checking service without interruption, PNM will no longer allow ring meter sockets as of 12/01/2013.

120/240V 100-125A Customer Overhead or Underground  
Single-Phase Meter Socket

MS-2-2.3

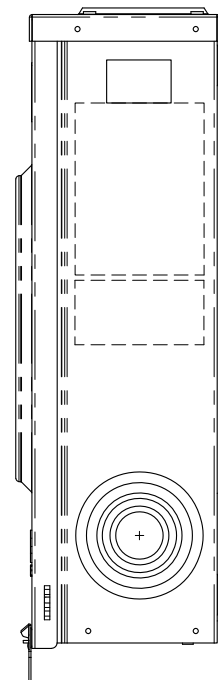
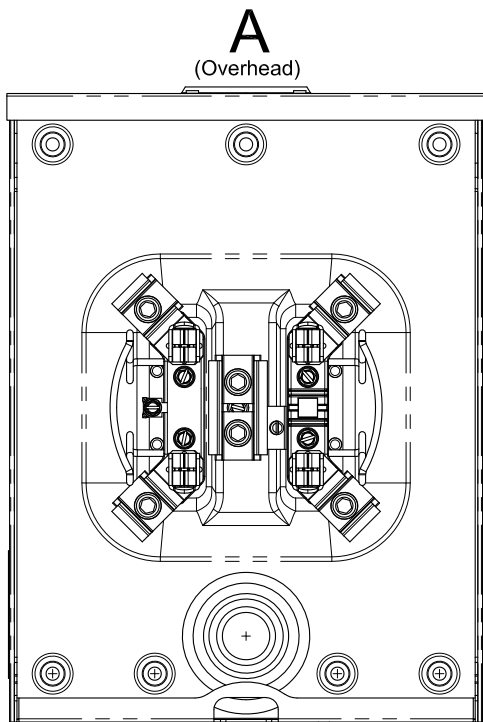

**Allowable Uses**

- 120/240 V  
Permanent/Temporary  
Services ONLY

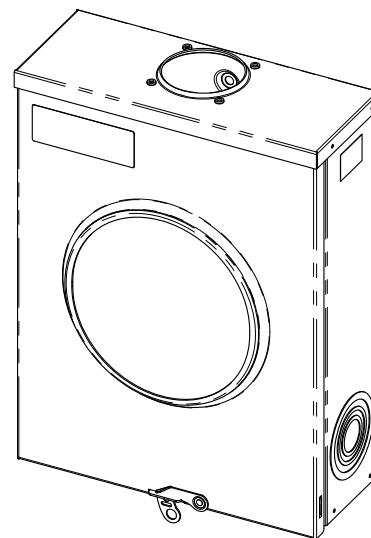
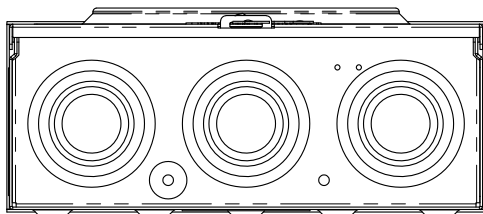

**NOTES**

- (1) Socket to be Underwriters Laboratory (UL) listed.
- (2) Connections for terminating service conductors shall be the lay-in type lug.
- (3) Service conduit to enter at point "A"
- (4) Meter shall be 4' - 5' 6" from finished grade.
- (5) Commercial application for non-critical loads i.e. sprinkler control and gates. PNM will allow socket without bypass handle.
- (6) PNM does not permit a trough ahead of meter socket.
- (7) Metering and instrument cabinets shall not be used to house Customer-owned equipment, such as distribution panels or other equipment, nor used as a junction box/trough for the distribution of circuits.
- (8) Customer building numbers must be permanently painted on proper meter panels.

**REFERENCES**

- (1) See DS-4-6.0 120/240V Underground Service Pole
- (2) See DS-4-8.0 Overhead Permanent/Temporary Single-Phase or Temporary Three-Phase Service Pole
- (3) See DS-4-9.0 Underground Residential Customer-Owned Service
- (4) See DM-4-11.0 Maximum Available Fault Current
- (5) See MS-3-7.0 Over 320A 240V Single-Phase Meter

Approved Equipment		
Manufacturer	Item	Mfg Part #
Eaton	200A OH Ringless Socket	UTRS202BCH
Eaton	200A OH/UG Ringless Socket	UTRS212BCH
Eaton	200A OH/UG Ringless Socket	UTRS213BE
Milbank	200A OH Ringless Socket	U7021-RL-TG
Milbank	200A OH Ringless Socket	U7040-RL-TG
Milbank	200A OH/UG Ringless Socket	U7040-XL-TG
Milbank	200A OH/UG Ringless Socket	U4801-XL-5T9
Milbank	200A OH/UG Ringless Socket	U8173-XL-KK-BLG
Siemens	200A OH Ringless Socket	SUAT317-0G
Siemens	200A OH Ringless Socket	UAT317-0G
Square D	200A OH Ringless Socket	UTRS202B
Square D	200A OH/UG Ringless Socket	UTH5213T
	(5th Jaw to be removed)	
Square D	200A OH/UG Ringless Socket	UTH7213T
Talon	200A OH Ringless Socket	UAT417-XGF

For ease of checking service without interruption, PNM will no longer allow ring meter sockets as of 12/01/2013.

240V 200A Customer Overhead or Underground  
Single-Phase Meter Socket

MS-2-2.5



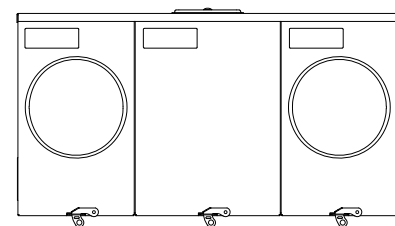
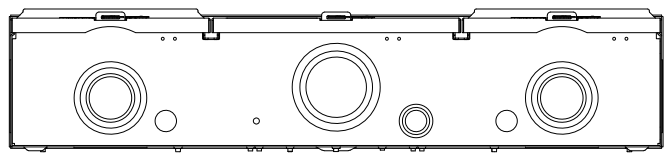
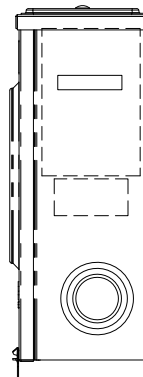
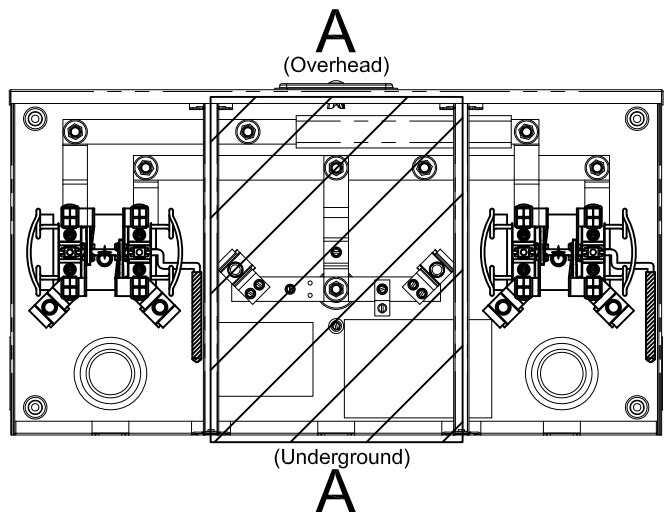

**NOTES**

- (1) Socket to be Underwriters Laboratory (UL) listed.
- (2) May be used on single-phase overhead and underground service.
- (3) Connections for terminating service conductors shall be the lay-in type.
- (4) Service conduit to enter at point "A"
- (5) PNM will make line termination on underground service only.
- (6) No load conduits or load conductors in shaded area from front to back.
- (7) Line section shall be lockable and sealable.
- (8) Customer building numbers must be permanently painted on proper meter panels.
- (9) Meter shall be 4' - 5' 6" from finished grade.
- (10) Commercial application require bypass handle.
- (11) Metering and instrument cabinets shall not be used to house Customer-owned equipment, such as distribution panels or other equipment, nor used as a junction box/trough for the distribution of circuits.
- (12) PNM requires 4 terminals, remove 5th terminal in field.

**REFERENCES**

- (1) See DS-4-5.0 Underground Service Entrance System
- (2) See DM-4-11.0 Maximum Available Fault Currents

Approved Equipment		
Manufacturer	Item	Mfg Part #
Eaton	200A OH/UG #-Gang Socket	UT*R2332UCH
Eaton	200A OH/UG Bypass Ringless Socket	UT3H52353TCH
Milbank	200A OH/UG 3-Gang Socket	U287*-XT-5T9
Siemens	200A OH/UG Bypass Ringless Socket	40405*-023NU
Siemens	200A OH/UG ___-Gang Socket	PowerMod (Commercial)

\* Denotes number of positions  
 There are various catalog #'s available for # of gang socket  
 For ease of checking service without interruption, PNM will no longer allow ring meter sockets as of 12/01/2013.

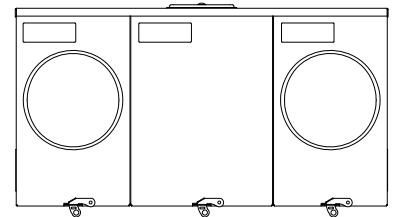
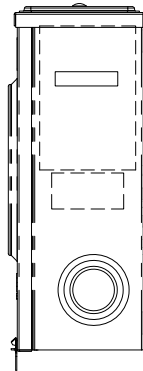
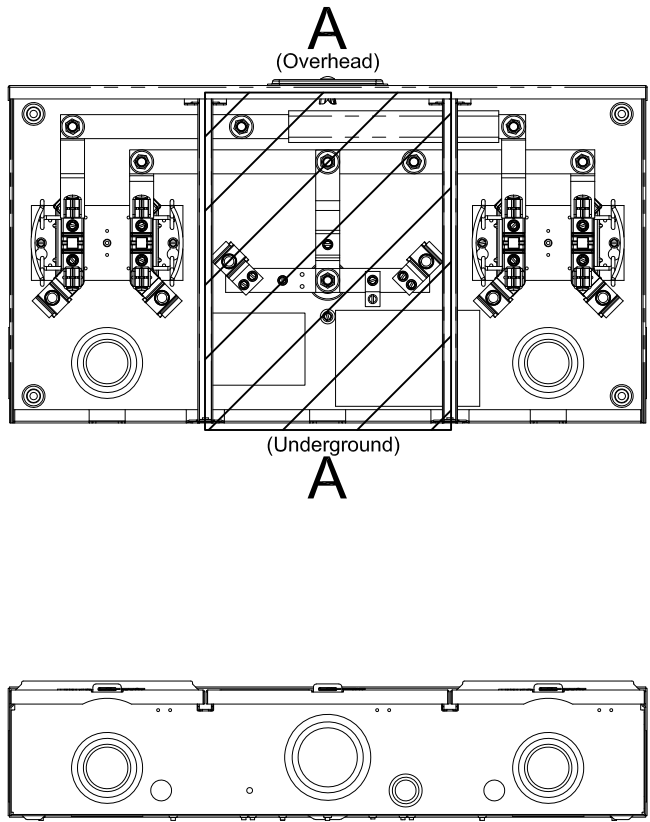

**NOTES**

- (1) Socket to be Underwriters Laboratory (UL) listed.
- (2) May be used on single-phase overhead and underground service.
- (3) Connections for terminating service conductors shall be the lay-in type.
- (4) Service conduit to enter at point "A"
- (5) PNM will make line termination on underground service only.
- (6) No load conduits or load conductors in shaded area from front to back.
- (7) Line section shall be lockable and sealable.
- (8) Customer building numbers must be permanently painted on proper meter panels.
- (9) Meter shall be 4' - 5' 6" from finished grade.
- (10) Commercial application require bypass handle.
- (11) Metering and instrument cabinets shall not be used to house Customer-owned equipment, such as distribution panels or other equipment, nor used as a junction box/trough for the distribution of circuits.

**REFERENCES**

- (1) See DS-4-5.0 Underground Service Entrance System
- (2) See DM-4-11.0 Maximum Available Fault Currents

Approved Equipment		
Manufacturer	Item	Mfg Part #
Eaton	200A OH/UG #-Gang Socket	UT*R2332BCH
Eaton	200A OH/UG #-Gang Socket	UT*R2332UCH
Eaton	200A OH/UG #-Gang Socket	UT*R2392UCH
Eaton	200A OH/UG #-Gang Socket	UT*R2392TTCH
Milbank	200A OH/UG #-Gang Socket	U125*-X-K1
Milbank	200A OH/UG #-Gang Socket	U125*-X-K3
Milbank	200A OH/UG #-Gang Socket	U125*-X-K4
Siemens	200A OH/UG #-Gang Socket	UA*716-XG
Siemens	200A OH/UG ___-Gang Socket	PowerMod (Residential)
Square D	200A OH/UG #-Gang Socket	MPR22-125

\* There are various catalog #'s available for # of gang socket  
For ease of checking service without interruption, PNM will no longer allow ring meter sockets as of 12/01/2013.

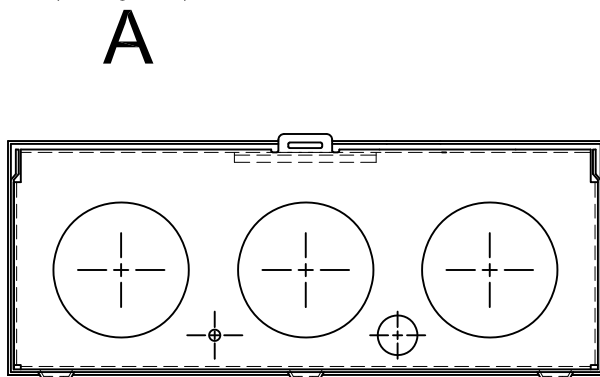
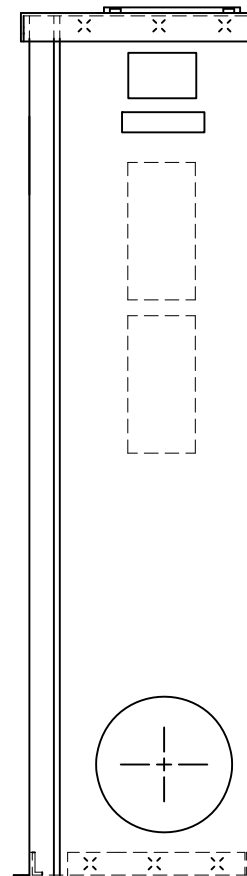
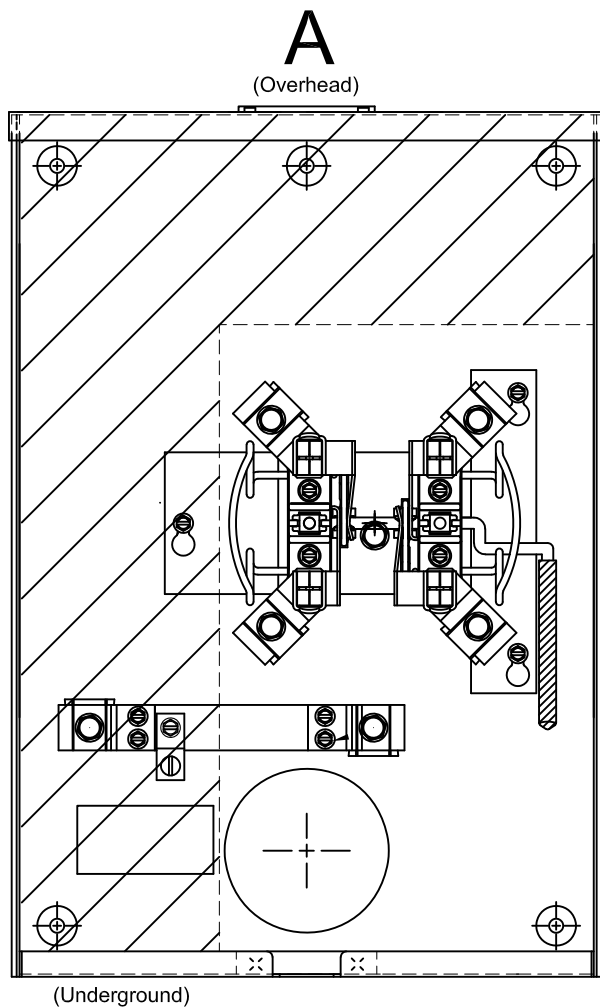

**SOCKET IS REQUIRED FOR  
PERMANENT COMMERCIAL  
INSTALLATIONS**

**NOTES**

- (1) Socket to be Underwriters Laboratory (UL) listed.
- (2) Connections for terminating service conductors shall be the lay-in type.
- (3) Service conduit to enter at points "A"
- (4) No load conduits or load conductors in shaded area from front to back.
- (5) May be used on single-phase overhead services up to and including 200A or 200A underground service.
- (6) This socket is optional for residential use.
- (7) Commercial application for non-critical loads, i.e. sprinkler controls and gates. PNM will allow socket without bypass handle.
- (8) Meter shall be 4' - 5' 6" from finished grade.
- (9) PNM does not permit a trough ahead of meter socket.
- (10) Metering and instrument cabinets shall not be used to house Customer-owned equipment, such as distribution panels or other equipment, nor used as a junction box/trough for the distribution of circuits.
- (11) Customer building numbers must be permanently painted on proper meter panels.

**REFERENCES**

- (1) See DS-4-5.0 Underground Service Entrance System
- (2) See DM-4-11.0 Maximum Available Fault Current

Approved Equipment		
Manufacturer	Item	Mfg Part #
Eaton	200A OH Ringless Socket	UTE5203BCH
Eaton	200A OH Ringless Socket	UTE4203BCH
Eaton	200A OH/UG Ringless Socket	UTE4213CCH
Milbank	200A OH/UG 4T Bypass Socket	U3852-XL
Milbank	200A OH/UG 4T Bypass Socket	U4801-XL-5T9
Siemens	200A OH/UG 4T Bypass Socket	40404-025
Square D	200A OH/UG 4T Bypass Socket	UTH7213T

For ease of checking service without interruption, PNM will no longer allow ring meter sockets as of 12/01/2013.

In the socket and at the weatherhead the colors green or white are not permitted to mark permanently phases one, two and three.

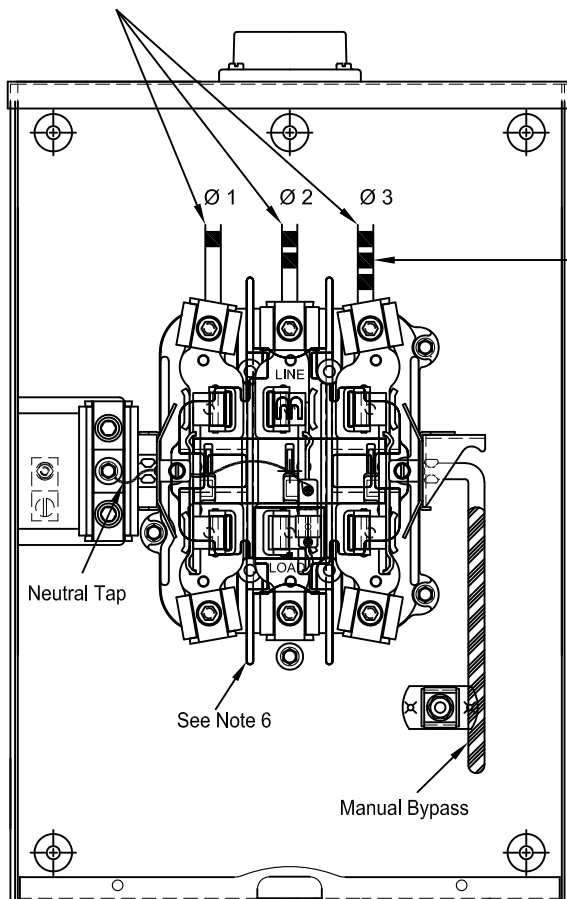

Phase three will be wild or high leg on **FOUR-WIRE DELTA SYSTEMS** and shall be permanently marked orange in color, in socket and at weatherhead.

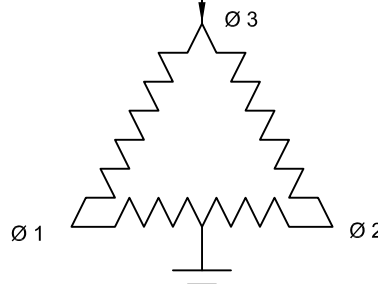
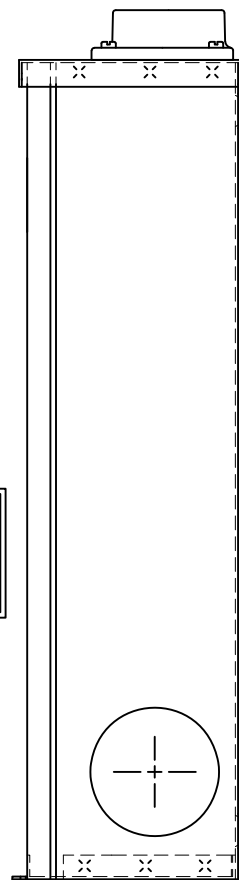

**Important:**

Socket shall be wired phase 1 - 2 - 3 from left to right and the conductors marked as such. Each conductor phase will be identified at the weather head or padmount, and at the meter base using band-wraps of electrical tape:  
 One band for phase one  
 Two bands for phase two  
 Three bands for phase three  
 White tape is suitable for neutral conductors only.

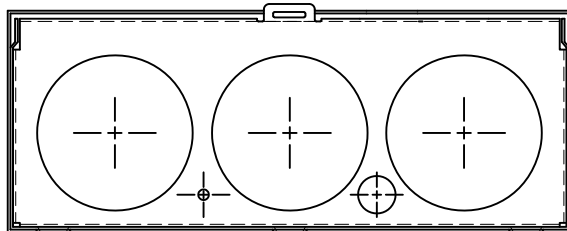

**NOTES**

- (1) Socket to be Underwriters Laboratory (UL) listed.
- (2) May be used on 120/208, Wye or 120/240 Delta services of 200A or less.
- (3) Socket shall be 200A class only.
- (4) Appropriate socket for overhead or underground shall be used.
- (5) Equipped with lever arm bypass with jaw tension release.
- (6) Transparent safety shield required.
- (7) Socket shall be wired by contractor.
- (8) Full sized neutral and three-phase conductors shall be installed into meter socket.
- (9) Meter shall be 4' - 5' 6" from finished grade.
- (10) Not to be used on 480V delta.
- (11) Metering and instrument cabinets shall not be used to house Customer-owned equipment, such as distribution panels or other equipment, nor used as a junction box/trough for the distribution of circuits.
- (12) Customer building numbers must be permanently painted on proper meter panels.
- (13) PNM does not permit a trough ahead of meter socket.

**REFERENCES**

- (1) See NEC 110.15
- (2) See DM-4-11.0 Maximum Available Fault Currents

Approved Equipment		
Manufacturer	Item	Mfg Part #
Durham	200A OH/UG Bypass Ringless Socket	UT-H7233U
Eaton	200A OH/UG Bypass Ringless Socket	UTE7203BCH
Eaton	200A OH/UG Bypass Ringless Socket	UTE7213BCH
Milbank	200A OH Bypass Ringless Socket	U9700-RRL
Milbank	200A OH/UG Bypass Ringless Socket	U9701-RXL
Siemens	200A OH/UG 7T Bypass Socket	40407-025

For ease of checking service without interruption, PNM will no longer allow ring meter sockets as of 12/01/2013.

In the socket and at the weatherhead the colors green or white are not permitted to mark permanently phases one, two and three.

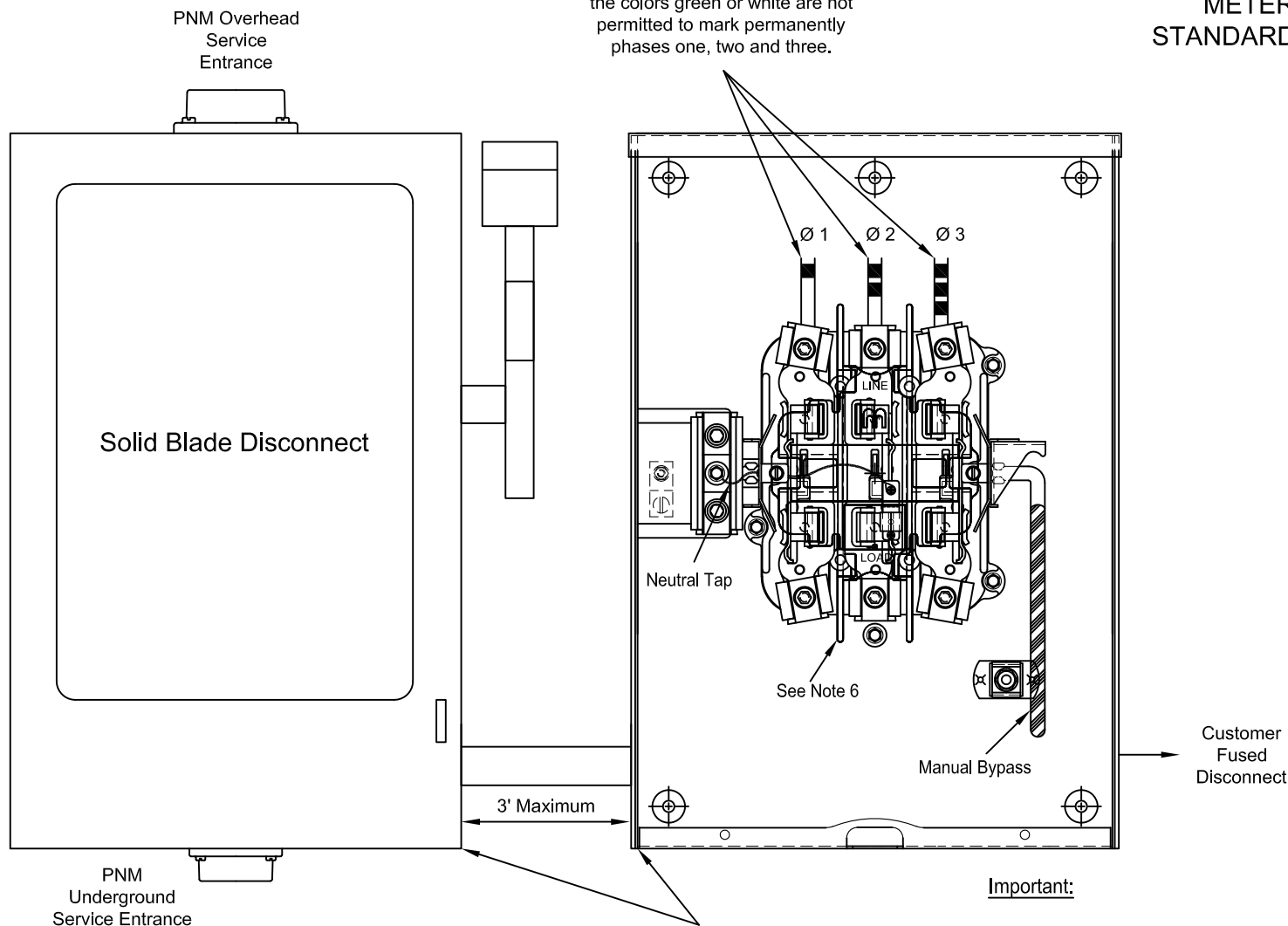

**NOTES**

- (1) Socket to be Underwriters Laboratory (UL) listed.
- (2) 277/480V Wye services of 200A or less.
- (3) Socket shall be 200A class only.
- (4) Appropriate socket for overhead or underground shall be used.
- (5) Equipped with lever arm bypass with jaw tension release.
- (6) Transparent safety shield required.
- (7) Customer shall install bonding system in accordance with NEC.
- (8) The load break switch is provided by the contractor.
- (9) The contractor shall wire the socket and the connections within the switch.
- (10) Full sized neutral and three-phase conductors shall be installed into meter socket.
- (11) Meter shall be 4' - 5' 6" from finished grade.
- (12) On a four-wire self contained service a lockable (for utility use) solid blade disconnect must be installed in front of meter base. Not required on temporary services.
- (13) Metering and instrument cabinets shall not be used to house Customer-owned equipment, such as distribution panels of other equipment, nor used as a junction box/trough for the distribution of circuits.
- (14) Customer building numbers must be permanently painted on proper meter panel.
- (15) PNM does not permit a trough ahead of meter socket.

**REFERENCES**

- (1) See DM-4-11.0 Maximum Available Fault Currents
- (2) See PNM Rule 16 paragraph C.1, solid blade disconnect is allowed and required.
- (3) See MS-2-6.0 120/208 Wye or 120/240 Delta 200A Three-Phase Four-Wire Wye or Delta Meter Socket with Bypass
- (4) See MS-5-3.0 Permanent Single-Phase or Three-Phase Pedestal Meter
- (5) See MS-5-4.0 Three-Phase or Single-Phase Overhead or Underground Field Built

Socket shall be wired phase 1 - 2 - 3 from left to right and the conductors marked in red tape as such. Each conductor phase will be identified at the weather head or padmount and at the meter base using band-wraps of electrical tape:

- One red band for phase one
- Two red bands for phase two
- Three red bands for phase three
- White tape is suitable for neutral conductors only.

Approved Equipment		
Manufacturer	Item	Mfg Part #
Durham	200A OH/UG Bypass Ringless Socket	UT-H7233U
Eaton	200A OH/UG Bypass Ringless Socket	UTE7203BCH
Eaton	200A OH/UG Bypass Ringless Socket	UTE7213BCH
Milbank	200A OH Bypass Ringless Socket	U9700-RRL
Milbank	200A OH/UG Bypass Ringless Socket	U9701-RXL
Siemens	200A OH/UG 7T Bypass Socket	40407-025
Manufacturer	Load Break Switch	Mfg Part #
Eaton	200A 600V NEMA3R Disconnect Switch	DH364URK
Murry	200A 600V NEMA3R Disconnect Switch	HUN364AW
Siemens	200A 600V NEMA3R Disconnect Switch	HNF364R
Square D	200A 600V NEMA3R Disconnect Switch	HU364RB

For ease of checking service without interruption, PNM will no longer allow ring meter sockets as of 12/01/2013.

**200A Three-Phase Four-Wire Wye  
277/480V Wye Meter Socket with Bypass**

**MS-2-6.3**

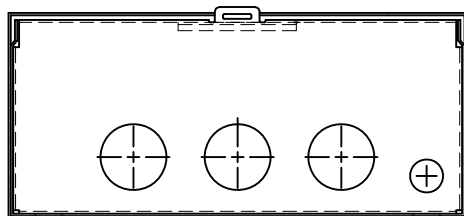
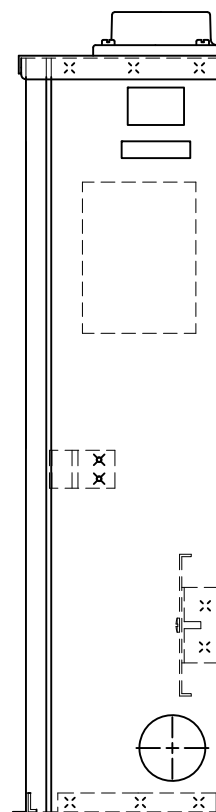
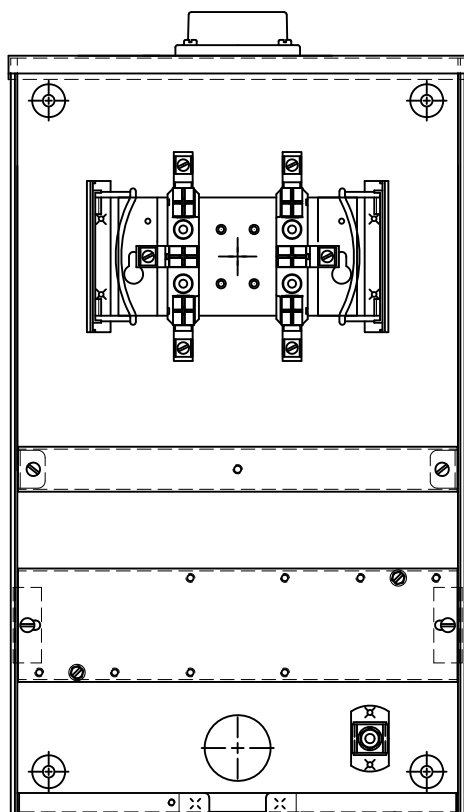

**NOTES**

- (1) Socket to be Underwriters Laboratory (UL) listed.
- (2) Socket shall be 20A class only.
- (3) Socket shall have two separate covers for meter and test switch compartments.
- (4) Latching bottom compartment shall lock both covers.
- (5) This applies to 100 and 167 kVA single-phase transformers only.
- (6) Meter shall be 4' - 5' 6" from finished grade.
- (7) Metering and instrument cabinets shall not be used to house Customer-owned equipment, such as distribution panels or other equipment, nor used as a junction box/trough for the distribution of circuits.
- (8) Customer building numbers must be permanently painted on proper meter panel.
- (9) PNM does not permit a trough ahead of meter socket.

**REFERENCES**

- (1) See MS-3-9.5 Single-Phase Bushing CT Meter Installation
- (2) See DM-4-11.0 Maximum Available Fault Currents

Approved Equipment		
Manufacturer	Item	Mfg Part #
Eaton	20A 6T Ringless Socket	USTS62BCH
Milbank	20A 6T Ringless Socket	UC3426-XL
Siemens	20A 6T Ringless Socket	9837-8243

For ease of checking service without interruption, PNM will no longer allow ring meter sockets as of 12/01/2013.

**Single-Phase Six-Terminal CT Meter Socket**

**MS-2-6.5**

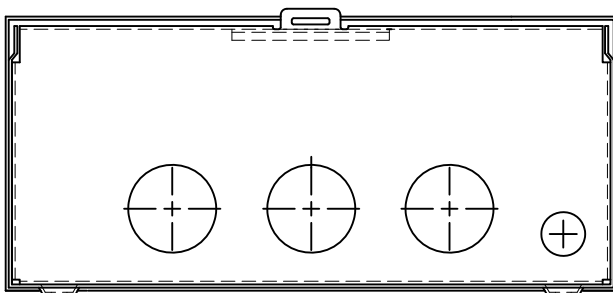
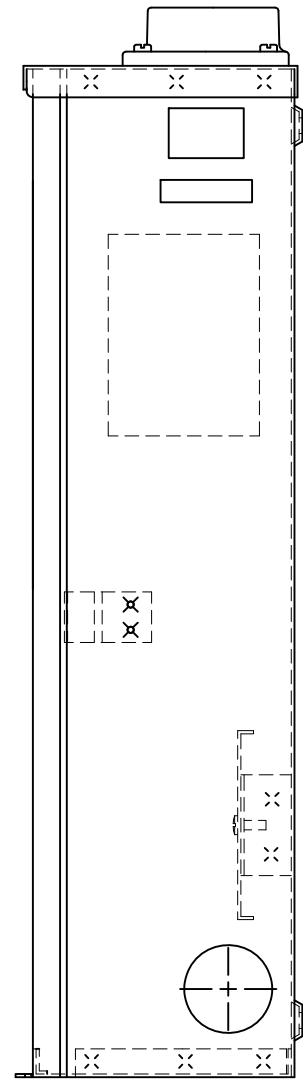
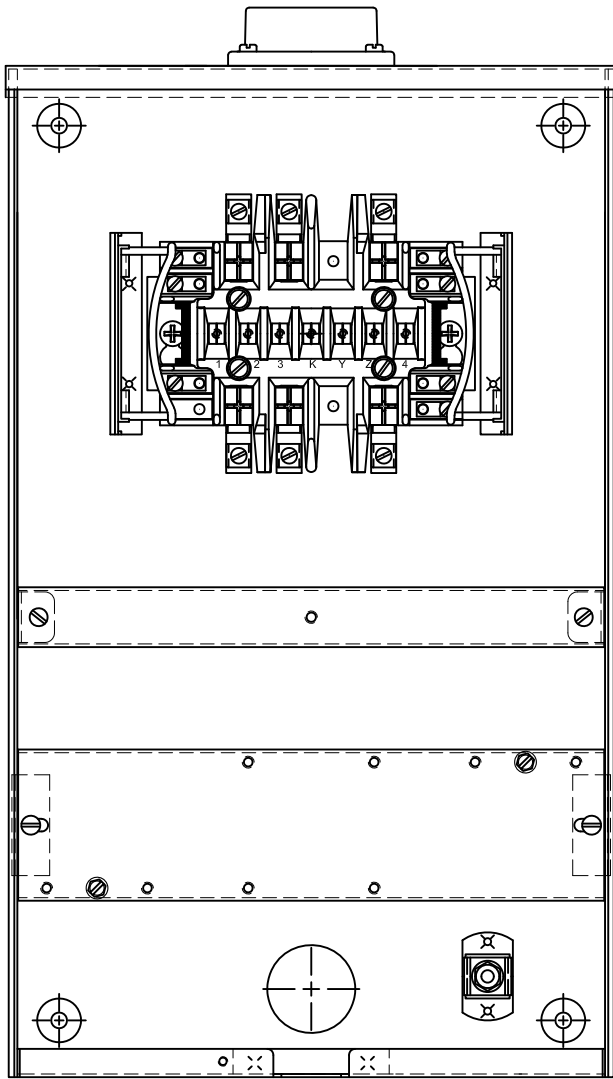

**NOTES**

- (1) Socket to be Underwriters Laboratory (UL) listed.
- (2) Socket shall be 20A class only.
- (3) Meter shall be 4' - 5' 6" from finished grade.
- (4) Socket shall have two separate covers for meter and test switch compartments.
- (5) Latching bottom compartment shall lock both covers.
- (6) Metering and instrument cabinets shall not be used to house Customer-owned equipment, such as distribution panels or other equipment, nor used as a junction box/trough for the distribution of circuits.
- (7) Customer building numbers must be permanently painted on proper meter panels.
- (8) PNM does not permit a trough ahead of meter socket.

Approved Equipment		
Manufacturer	Item	Mfg Part #
Eaton	20A 13T Ringless Socket	USTS132CCH
Milbank	20A 13T Ringless Socket	UC3423-XL
Milbank	20A 13T Ringless Socket	UC3423-XL-13
Siemens	20A 13T Ringless Socket	9837-8500
Siemens	20A 13T Ringless Socket	9837-8501
Siemens	20A 13T Ringless Socket	9837-8502
Siemens	20A 13T Ringless Socket	9837-8503
Siemens	20A 13T Ringless Socket	9837-8543

For ease of checking service without interruption, PNM will no longer allow ring meter sockets as of 12/01/2013.

**Three-Phase Thirteen-Terminal CT Meter Socket**

**MS-2-7.0**

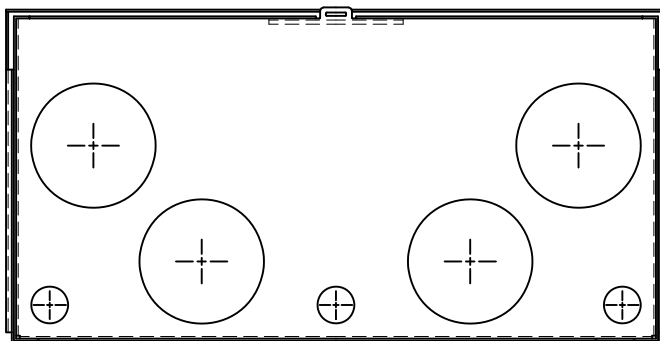
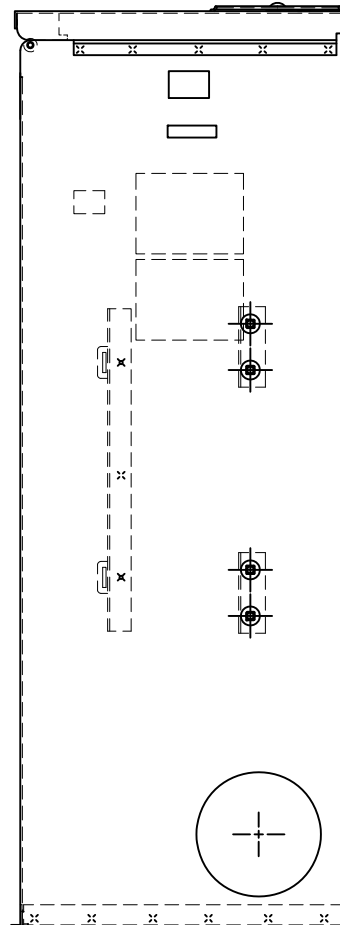
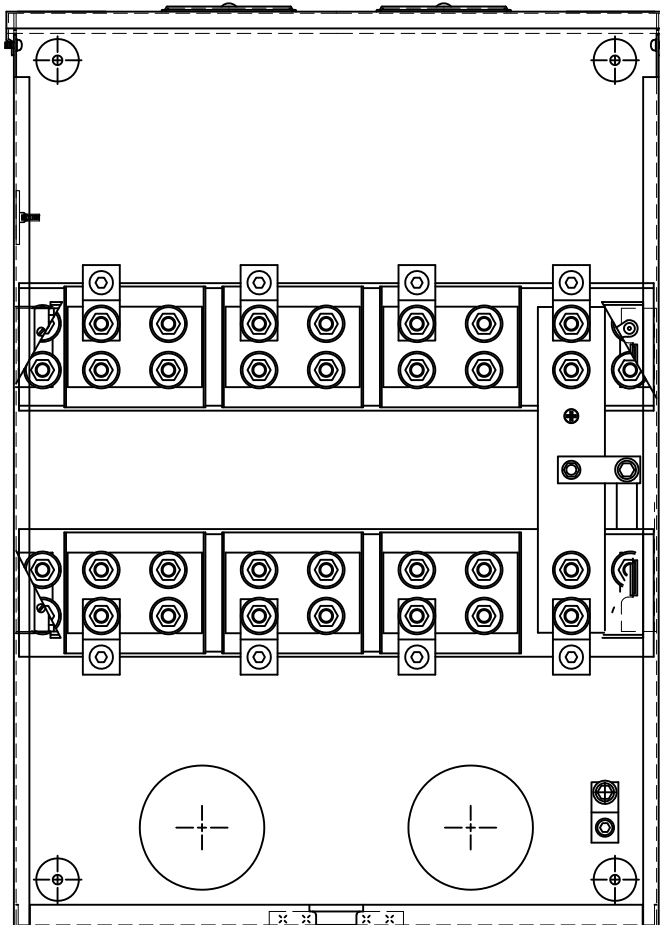

**NOTES**

- (1) Socket to be Underwriters Laboratory (UL) listed.
- (2) Meter shall be 4' - 5' 6" from finished grade.
- (3) Metering and instrument cabinets shall not be used to house Customer-owned equipment, such as distribution panels or other equipment, nor used as a junction box/trough for the distribution of circuits.
- (4) Customer building numbers must be permanently painted on proper meter panels.
- (5) PNM does not permit a trough ahead of meter socket.

Approved Equipment		
Manufacturer	Item	Mtg Part #
Milbank	3 Phase 13 T Ringless Trans Socket	U2161-XT
Milbank	1 Phase 6 T Ringless Trans Socket	U2228-XT

For ease of checking service without interruption, PNM will no longer allow ring meter sockets as of 12/01/2013.

Ringless Trans Socket

MS-2-8.0



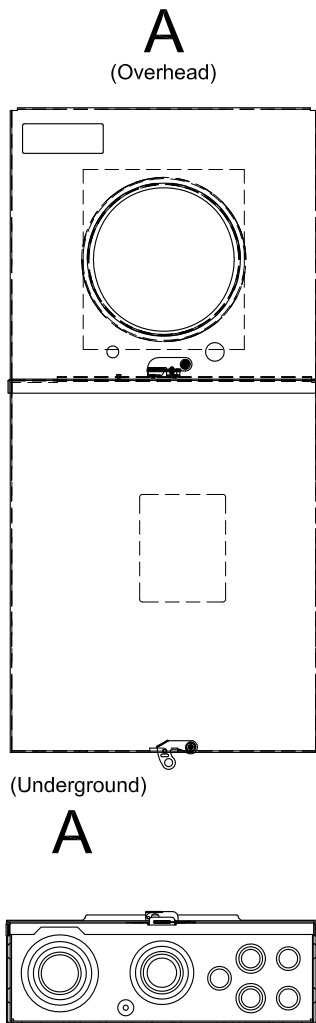

**Allowable Uses**

- Permanent 240V Overhead and Customer Owned Underground.
- Temporary Overhead and Temporary Underground Service.
- Permanent 240V Underground PNM Service <100' Maximum or Less than (4/0 Underground Cable, NOT Approved for 350 Underground Cable)

**NOTES**

- (1) Socket to be Underwriters Laboratory (UL) listed.
- (2) Connections for terminating service conductors shall be the lay-in type.
- (3) Service conduit to enter at point "A"
- (4) Permanent 240V overhead, customer owned underground, permanent 240V underground PNM Service <100' Maximum or less than (4/0 underground cable), or overhead and underground temporary service only.
- (5) Meter shall be 4' - 5' 6" from finished grade.
- (6) Commercial application for non-critical loads, i.e. sprinkler control and gates. PNM will allow socket without bypass handle.
- (7) PNM does not permit a trough ahead of meter socket.
- (8) Metering and instrument cabinets shall not be used to house Customer-owned equipment, such as distribution panels or other equipment, nor used as a junction box/trough for the distribution of circuits.
- (9) Customer building numbers must be permanently painted on proper meter panels.
- (10) 125A is only applicable for manufactured, mobile homes, temporary overhead and underground service and replacing existing 100A or less meter socket.
- (11) PNM does not permit a trough ahead of meter socket.

**REFERENCES**

- (1) See DS-4-6.0 120/240V Underground Temporary Service Pole
- (2) See DS-4-8.0 Overhead Permanent/Temporary Single-Phase or Temporary Three-Phase Service Pole
- (3) See DS-4-9.0 Underground Residential Customer-Owned Service
- (4) See DM-4-11.0 Maximum Available Fault Current
- (5) See MS-3-7.0 Over 320A 240V Single-Phase Meter Options

Approved Equipment		
Manufacturer	Item	Mfg Part #
Eaton	200A OH/UG Ringless w/Gasket	MB(***)w/ Gasket
Eaton **	200A OH/UG Ringless	MB2040PV200BTS
Leviton	200A OH/UG Ringless 8T Socket	LP820-TMC
Milbank	200A OH/UG Ringless 4T Socket	U5168-XTL-200
Milbank	200A OH/UG Ringless Socket	U4801-XL-5T9
Milbank	200A OH/UG Ringless 20T Socket	U5268-XTL-200
Siemens	200A OH/UG Ringless 16T Socket	MC0816B1200RCT
Siemens	200A OH/UG Ringless 16T Socket	MC0816B1200JLT
Siemens	200A OH/UG Ringless 16T Socket	MC2040B1200R
Siemens	200A OH/UG Ringless 16T Socket	MC2040B1200JLC
Siemens	200A OH/UG Ringless 30T Socket	MC3040B1200R
Siemens	Residential ONLY 200A OH/UG Ringless 30T Socket	MC3042B1200RC
Siemens	Residential ONLY 200A OH/UG Ringless 40T Socket	MC2040B1200RC
Square D	Residential ONLY 200A OH/UG Ringless 8T Socket	RC816F200S
Square D	200A OH/UG Ringless 16T Socket	RC816F200C
Square D	Residential ONLY 100A OH/UG Ringless 16T Socket	RC1624M100S
Square D	200A OH/UG Ringless 20T Socket	RC2040M200SS
Square D	200A OH/UG Ringless 20T Socket	RC2040M200S
Square D	200A OH/UG Ringless 30T Socket	RC3042M200PS
Square D	200A OH/UG Ringless 40T Socket	RC2040M200C

\*\* 225A buss makes solar tie ready, eliminating the need for supply side connection.

\*\*\* There are various catalog # available when gasket is included.

For ease of checking service without interruption, PNM will no longer allow ring meter sockets as of 12/01/2013.

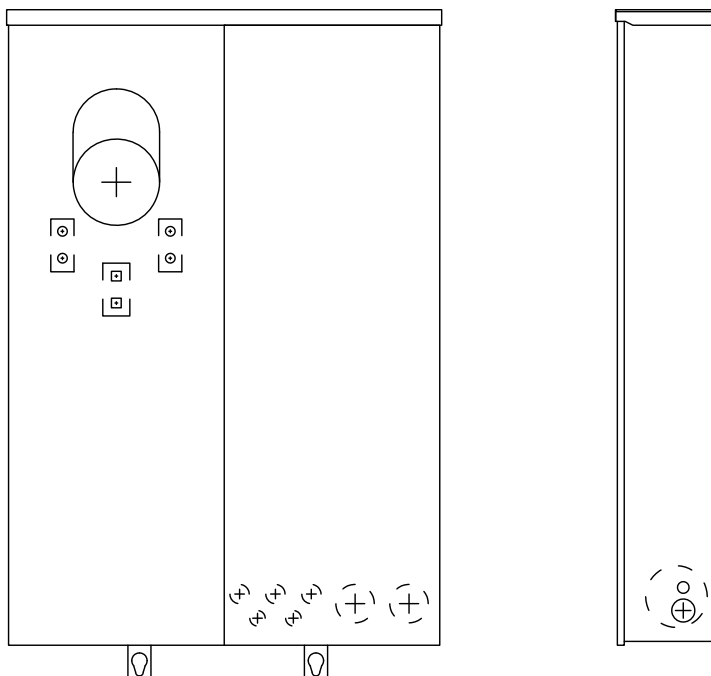

(Underground)

**A**

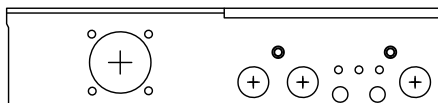

**Allowable Uses**

- Permanent 240V Overhead and Customer Owned Underground.
- Temporary Overhead and Temporary Underground Service.
- Permanent 240V Underground PNM Service <100' Maximum or Less than (4/0 Underground Cable, NOT Approved for 350 Underground Cable)

**NOTES**

- (1) Socket to be Underwriters Laboratory (UL) listed.
- (2) Connections for terminating service conductors shall be the lay-in type.
- (3) May be used on Single-Phase Overhead or Underground services in excess of 200A but not to exceed 300A residential or 300A commercial. The total capacity of the Main Breakers cannot exceed 300A (i.e.: 1 @200A + 1 @ 100A, 2 @ 150A, etc.), 400A Fused Disconnects with reduced size fusing are Not Allowed. No Buss Overcurrent Protection rated above 300A Total will be allowed. If used on a Commercial Service a Lever Operated Bypass is Required.
- (4) Service conduit to enter at point "A"
- (5) Permanent 240V overhead, customer owned underground, permanent 240V underground PNM Service <100' Maximum or less than (4/0 underground cable), or overhead and underground temporary service only.
- (6) Meter shall be 4' - 5' 6" from finished grade.
- (7) Commercial application for non-critical loads, i.e. sprinkler control and gates. PNM will allow socket without bypass handle.
- (8) PNM does not permit a trough ahead of meter socket.
- (9) Metering and instrument cabinets shall not be used to house Customer-owned equipment, such as distribution panels or other equipment, nor used as a junction box/trough for the distribution of circuits.
- (10) Customer building numbers must be permanently painted on proper meter panels.
- (11) PNM does not permit a trough ahead of meter socket.

**REFERENCES**

- (1) See DS-4-6.0 120/240V Underground Temporary Service Pole
- (2) See DS-4-8.0 Overhead Permanent/Temporary Single-Phase or Temporary Three-Phase Service Pole
- (3) See DS-4-9.0 Underground Residential Customer-Owned Service
- (4) See DM-4-11.0 Maximum Available Fault Current
- (5) See MS-3-7.0 Over 320A 240V Single-Phase Meter

320A UG Ringless 24T Socket

Approved Equipment		
Manufacturer	Item	Mfg Part #
Eaton	320A UG Ringless 40T Socket	HP30SH
Eaton	320A UG Ringless 24T Socket	U4042MCC
Siemens	320A UG Ringless 24T Socket	MC2442B1300SDL

For ease of checking service without interruption, PNM will no longer allow ring meter sockets as of 12/01/2013.

**240V 320A Single-Phase Combo Meter Socket  
Underground Residential ONLY**

**MS-2-9.5**

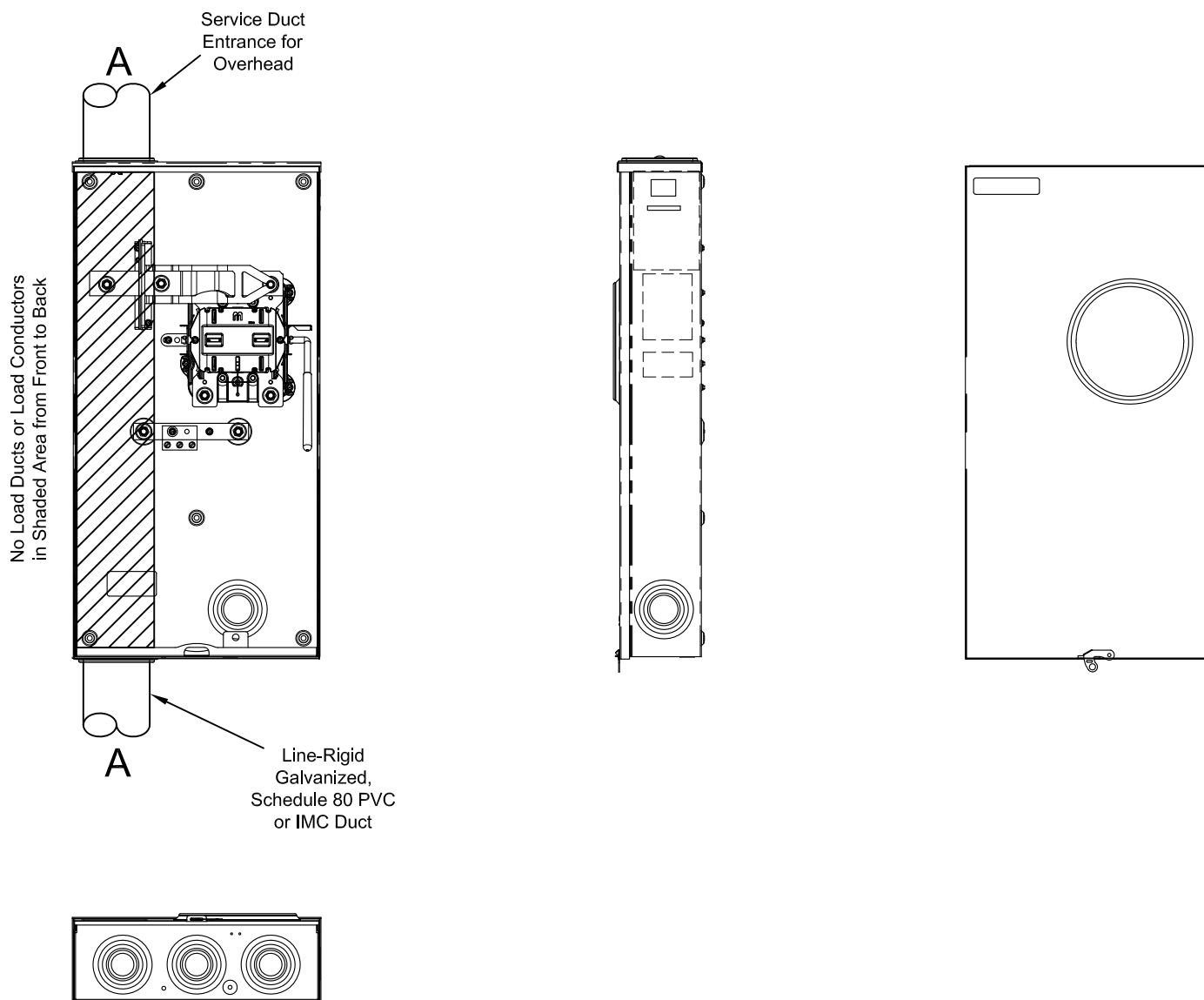

**NOTES**

- (1) Check with PNM for sizing of duct on underground services.
- (2) Enclosure shall be securely mounted to building.
- (3) May be used on Single-Phase Overhead or Underground services in excess of 200A but not to exceed 300A residential or 300A commercial. The total capacity of the Main Breakers cannot exceed 300A (i.e.: 1 @ 200A + 1 @ 100A, 2 @ 150A, etc.). 400A Fused Disconnects with reduced size fusing are Not Allowed. No Buss Overcurrent Protection rated above 300A Total will be allowed. If used on a Commercial Service a Lever Operated Bypass is Required.
- (4) Service duct to enter at points "A".
- (5) Connections for terminating service conductors shall be the lay-in type.
- (6) Meter shall be 4' - 5' 6" from final grade.
- (7) PNM will make line termination on underground services only.
- (8) Equipped with lever arm bypass with jaw tension release.
- (9) Metering and instrument cabinets shall not be used to house Customer-owned equipment, such as distribution panels or other equipment, nor used as a junction box/trough for the distribution of circuits.
- (10) Customer building numbers must be permanently painted on proper meter panel.
- (11) PNM does not permit a trough ahead of meter socket.

Approved Equipment		
Manufacturer	Item	Mfg Part #
Eaton	320A OH/UG Meter Base	UT-H4336-9T-CH
Eaton	320A UG Meter Base	MC2442B1300SDL
Eaton	320A OH/UG Meter Base Bypass	HPC4046SHLG
Eaton	320A OH/UG Meter Base Bypass	HP40SHL
Milbank	320A UG Meter Base	U1797-O-K3L-K2L
Milbank	320A OH/UG Meter Base Bypass	U1029-X-DPL
Milbank	320A OH/UG Meter Base Bypass	U1079-RRL-K3
Milbank	320A OH/UG Meter Base	U2448-X
Square D	320A OH/UG Meter Base Bypass	UTH4330T
Square D	320A OH/UG Meter Base Bypass	1009788A

For ease of checking service without interruption, PNM will no longer allow ring meter sockets as of 12/01/2013.

320A Meter Socket with Bypass

MS-2-10.0

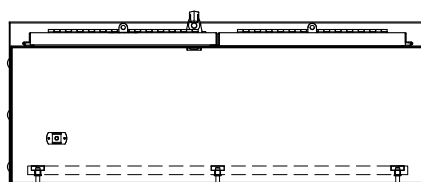
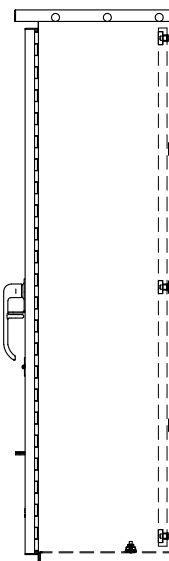
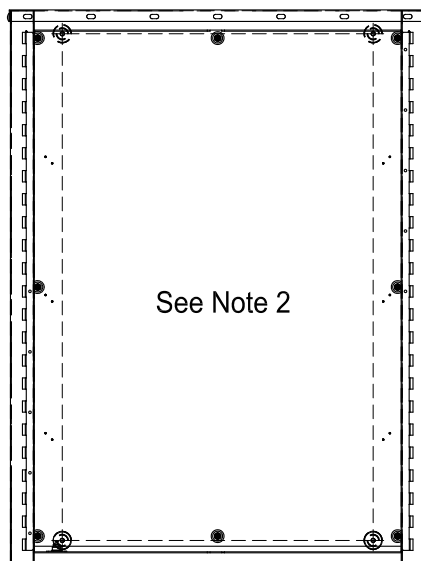
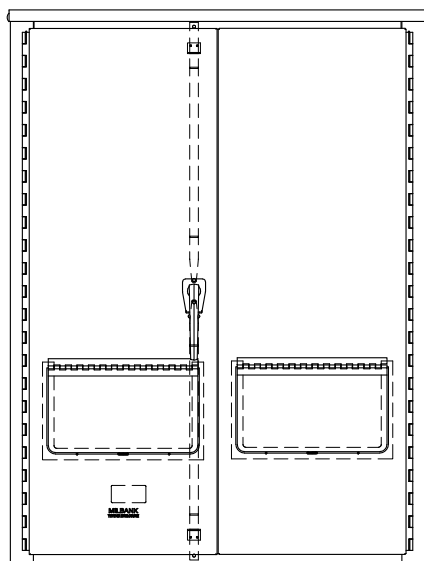

NOTES

- (1) Fourteen gauge galvanized steel, painted.
- (2) Contractor must furnish full 3/4" plywood back.
- (3) Opening in both doors, no glass, fitted with hinged flap covers, and lockable latch.
- (4) Door shall have latch and lockable handle.

Approved Equipment		
Manufacturer	Item	Mfg Part #
Eastern-Owens	Enclosure	EOT-24
Hoffman	Enclosure	BN830ASY
Milbank	Enclosure	364812-CT3R-SP2
Nvent	Enclosure	A483612CTPNMW2
Sunwest	Enclosure	SW-1982 W2

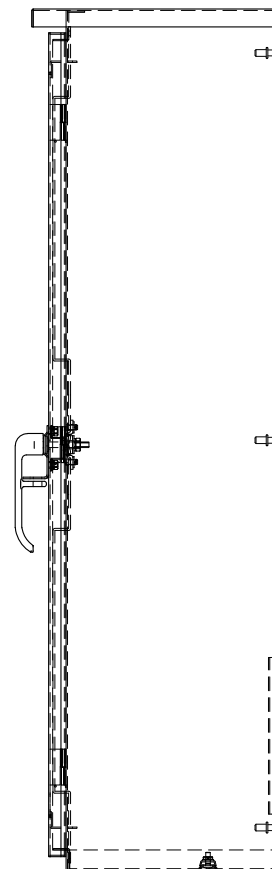
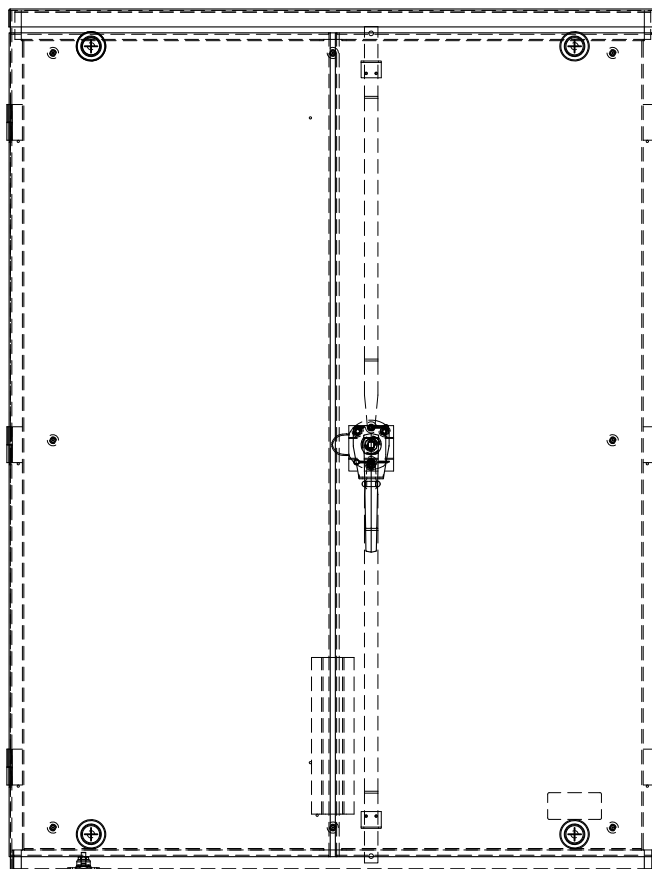

See Note 3

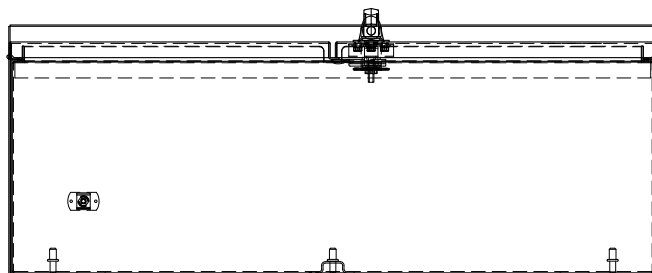

NOTES

- (1) 14 gauge galvanized steel, painted.
- (2) Door shall have latch and lockable handle.
- (3) Contractor must furnish full 3/4" plywood back.

Approved Equipment		
Manufacturer	Item	Mfg Part #
Eastern-Owens	Enclosure	EOT-82
Hoffman	Enclosure	BN829ASY
Milbank	Enclosure	364812-CT3R-WB
Milbank	Enclosure	364812-CT3R-SP2
Nvent	Enclosure	A483612CTPNM
Sunwest	Enclosure	SW-1982 W0

A

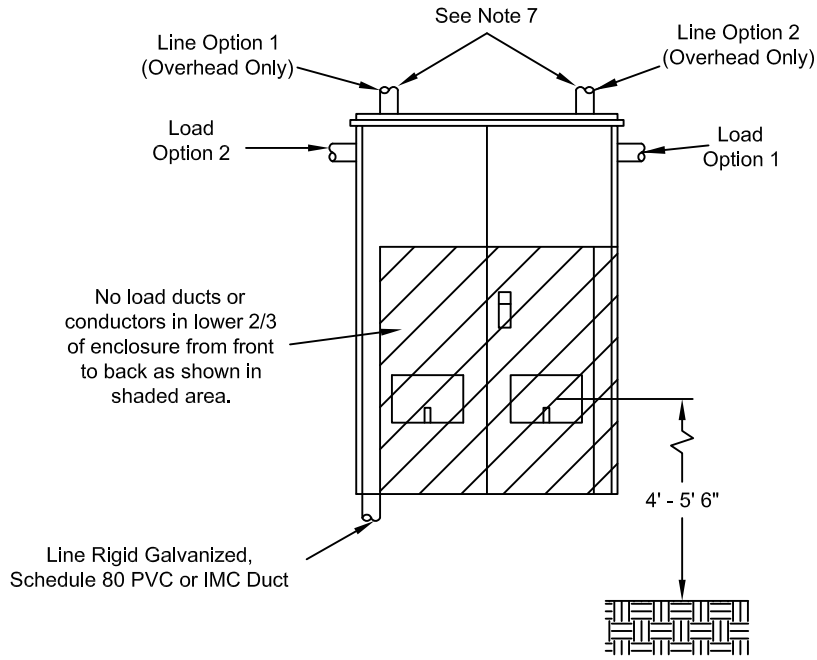

B

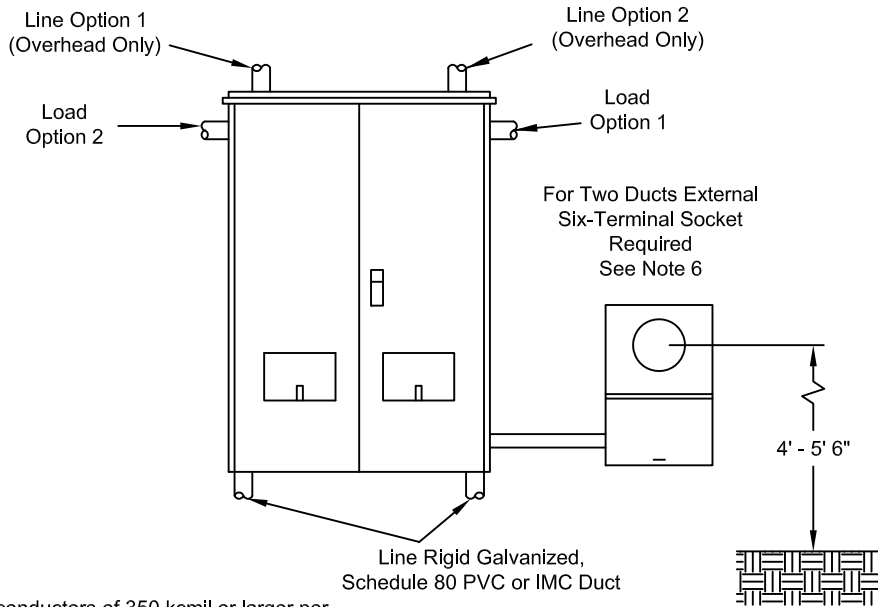

**NOTES**

- (1) Enclosure must be used when parallel conductors of 350 kcmil or larger per phase are installed. (600A main disconnect or larger)
- (2) Must have 3/4" plywood backing inside enclosure installed by contractor.
- (3) Use only one of two load options.
- (4) Enclosure shall be securely mounted to building.
- (5) Line and load options shall be on different quarter section.
- (6) If the number of runs or duct size meets that allowed by Table A, use MS-2-6.5.
- (7) When using load out top of CT can, a J-Box or LB must be used within 2' of existing can. The same will be for single-phase ITT when coming in underground and exiting out top side with load conductors.
- (8) 1-2-3 to be identified in RED, Neutral in WHITE. For Delta services the third (wild) leg in ORANGE. Leave wire rolled up in CT can and ensure the wire is long enough to reach Main Disconnect Panel (MDP)

**REFERENCES**

- (1) See MS-2-6.5 Single-Phase Six-Terminal CT Meter Socket
- (2) See MS-3-2.0 Double-Window Three-Phase Instrument Transformer and Meter Enclosure

Table A

Allowed Number of Ducts	Maximum Conductors Size
2	750 kcmil Overhead ONLY
3	500 kcmil
4	Not Allowed
Maximum Three Conductors Per Duct	

All conduits or nipples exiting a CT enclosure will be the same size as the entrance conduits without exception.

Over 320A 240V Single-Phase Meter

MS-3-7.0

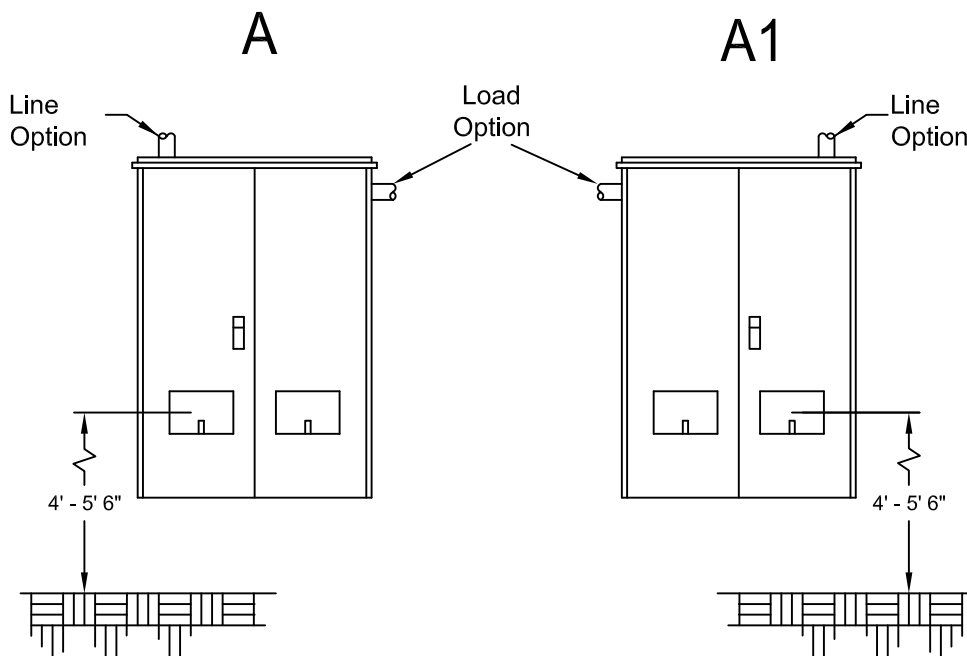

**Important:**

Socket shall be wired phase 1-2-3 from left to right and the conductors marked as such. Each conductor phase will be identified at the weather head or padmount, and at the meter base using band-wraps of electrical tape:

- One band for phase one
- Two bands for phase two
- Three bands for phase three
- White tape is suitable for neutral conductors only.

**NOTES**

- (1) MS-3-2.0 Double-Window Three-Phase Instrument Transformer and Meter Enclosure
- (2) Must be used when main switch is larger than 200A.
- (3) Use only one of the options.
- (4) Must have 3/4" plywood backing inside enclosure.
- (5) If ducts or conductors cannot be kept out of shaded area due to parallel or large conductors, MS-3-8.0 drawings B must be used.
- (6) Maximum of two runs of 500 kcmil cable in a maximum of two ducts.
- (7) Line and load options shall be on different quarter section.
- (8) 1-2-3 to be identified in RED, Neutral in WHITE. For Delta services the third (wild) leg in ORANGE.  
Leave wire rolled up in CT can and ensure the wire is long enough to reach Main Disconnect Panel (MDP)

Table A

Allowed Number of Ducts	Maximum Conductors Size
1	750 kcmil Overhead ONLY
2	500 kcmil
3	Not Allowed
Maximum 4 Conductors Per Duct	

All conduits or nipples exiting a CT enclosure will be the same size as the entrance conduits without exception

Over 200A Three-Phase Overhead Meter

MS-3-7.5

A

Underground Service

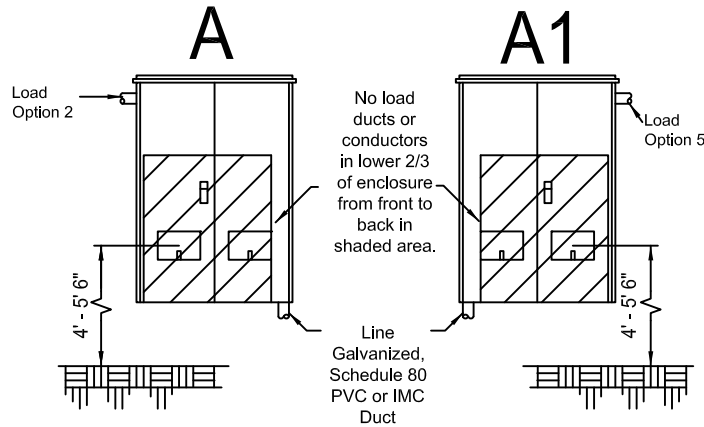

**Important:**

Socket shall be wired phase 1-2-3 from left to right and the conductors marked as such. Each conductor phase will be identified at the weather head or padmount, and at the meter base using band-wraps of electrical tape:

- One band for phase one
- Two bands for phase two
- Three bands for phase three
- White tape is suitable for neutral conductors only

**NOTES**

- (1) MS-3-2.0 Double-Window Three-Phase Instrument Transformer and Meter Enclosure
- (2) Must be used when main switch is larger than 200A.
- (3) Use only one of the options.
- (4) Must have 3/4" plywood backing inside enclosure.
- (5) If ducts or conductors cannot be kept out of shaded area due to parallel or large conductors. Drawings B must be used.
- (6) Maximum of 2 runs of 500 kcmil cable in a maximum of 2 ducts.
- (7) Line and load options shall be on different quarter section.
- (8) 1-2-3 to be identified in RED, Neutral in WHITE. For Delta services the third (wild) leg in ORANGE. Leave wire rolled up in CT can and ensure the wire is long enough to reach Main Disconnect Panel (MDP)

B

Underground Service

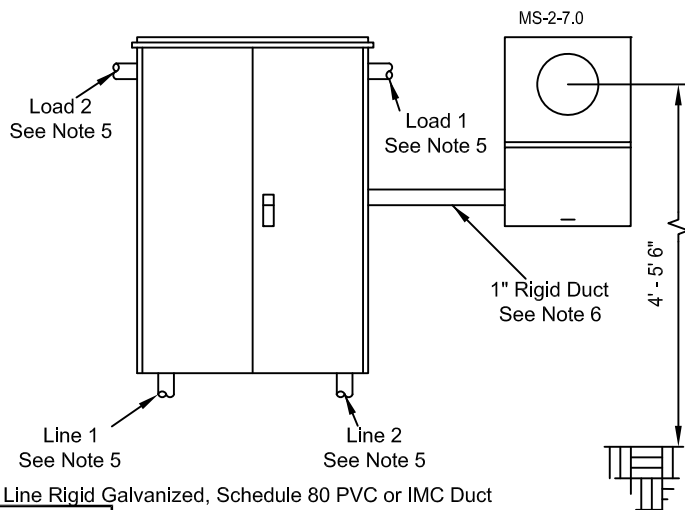

Table A

Allowed # of Ducts	Maximum Conductors Size
2	750 kcmil
3	500 kcmil
4	Not Allowed
Maximum Four Conductors Per Duct	

**NOTES**

- (1) MS-2-7.0 Three-Phase Thirteen-Terminal Socket for CT Meter
- (2) MS-3-3.0 Recording Meter Instrument Transformer Enclosure
- (3) Line and load options shall be on opposite quarter section.
- (4) If the number of runs or duct size meets that allowed by table A, use MS-3-3.0 or MS-3-11.0 enclosure.
- (5) Use only one of the four load options.
- (6) Contractor shall install a 1" rigid duct between transformer enclosure and meter enclosure. This duct shall not exceed 30'. It shall be an unbroken run of conduit/wire containing no condulets.
- (7) All enclosures (drawings A and B) shall be securely mounted to building
- (8) Line and load options shall be on opposite quarter section.
- (9) 1-2-3 to be identified in RED, Neutral in WHITE. For Delta services the third (wild) leg in ORANGE. Leave wire rolled up in CT can and ensure the wire is long enough to reach Main Disconnect Panel (MDP)

All conduits or nipples exiting a CT enclosure will be the same size as the entrance conduits without exception

Over 200A Three-Phase Underground Meter

MS-3-8.0



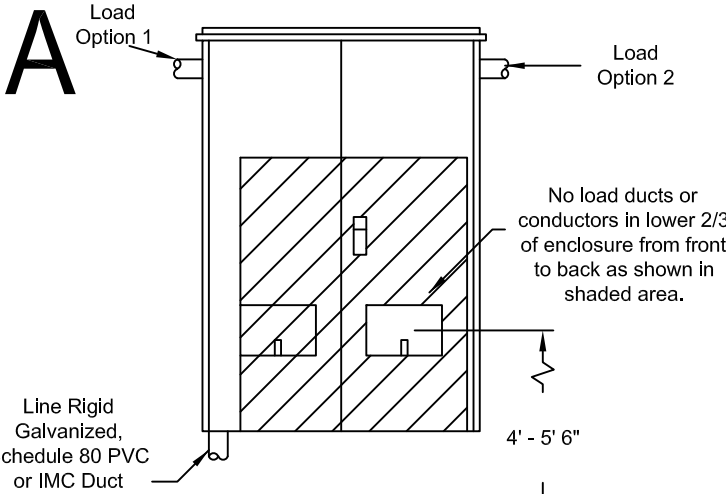

Table A

Allowed # of Ducts	Maximum Conductors Size
2	750 kcmil
3	500 kcmil
4	Not Allowed
Maximum Four Conductors Per Duct	

All conduits or nipples exiting a CT enclosure will be the same size as the entrance conduits without exception

**NOTES**

- (1) MS-3-2.0 Double-Window Three-Phase Instrument Transformer and Meter Enclosure
- (2) Must be used when main switch is 200A or less.
- (3) Use one only of four load options.
- (4) Must have 3/4" plywood backing inside enclosure.
- (5) Coordinate duct size with PNM (line ducts).
- (6) Line and load options shall be on different quarter section.

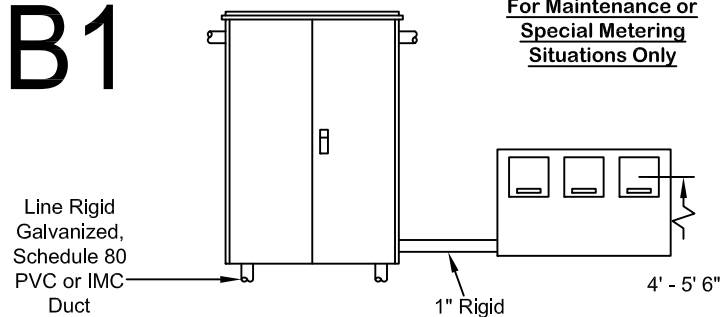
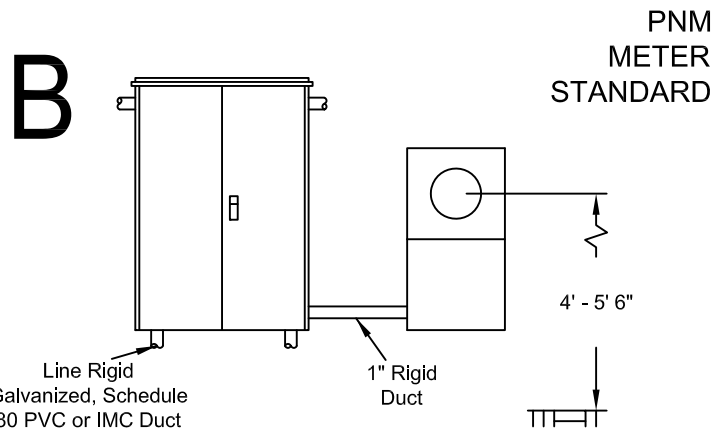

**For Maintenance or Special Metering Situations Only**

**NOTES**

- (1) MS-2-7.0 Three-Phase Thirteen-Terminal for CT Meter
- (2) MS-3-3.0 Recording Meter Instrument Transformer Enclosure
- (3) MS-3-4.0 Triplex Meter Enclosure
- (4) Conductor size may not exceed a single run of 750 MCM.
- (5) Load and load options shall be on different quarter section.
- (6) Must have 3/4" plywood backing inside enclosure.
- (7) Coordinate duct size with PNM (line ducts).
- (8) Must be used when main switch is larger than 100A.

**Important:**

Socket shall be wired phase 1-2-3 from left to right and the conductors marked as such. Each conductor phase will be identified at the weather head or padmount, and at the meter base using band-wraps of electrical tape: one band for phase one, two bands for phase two, and three bands for phase three. White tape is suitable for neutral conductors only.

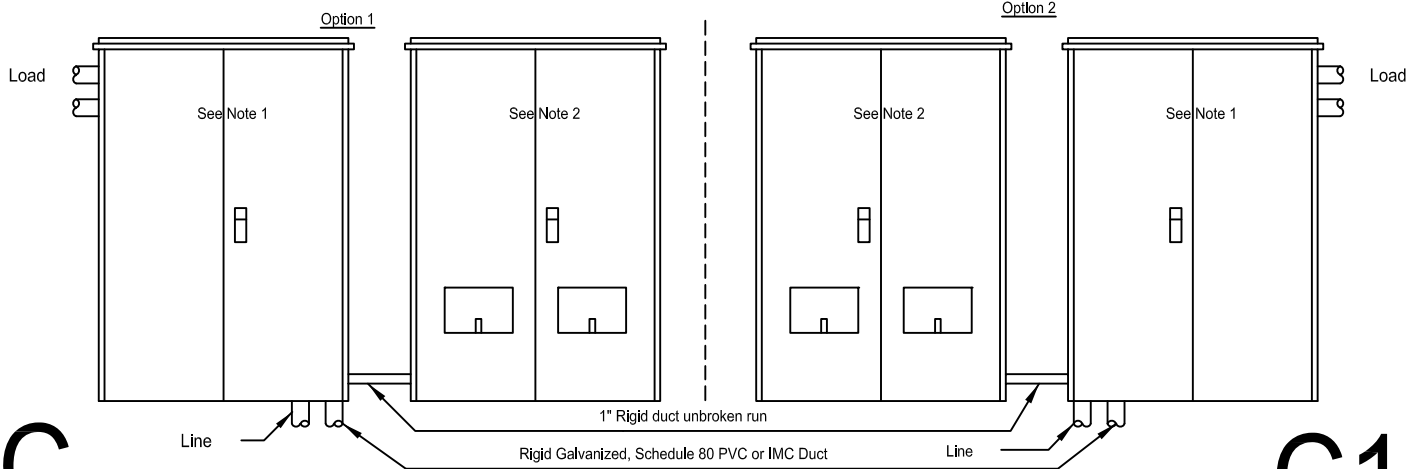

**NOTES**

- (1) MS-3-3.0 Recording Meter Instrument Transformer Enclosure
- (2) MS-3-4.0 Triplex Meter Enclosure
- (3) Both enclosures must be used when parallel conductors exceeds 350MCM and shall not exceed 750MCM parallel conductors per phase.
- (4) Only option C or option C1 can be used due to space. Ducts must enter and leave per drawing above.
- (5) 1" rigid duct installed by contractor, shall not exceed 30' and shall be continuous run of duct/wire containing no condulets.
- (6) Must have 3/4" plywood backing inside enclosure.
- (7) All enclosures (drawings A, B and C) shall be securely mounted to building.
- (8) Coordinate duct size with PNM (line ducts).

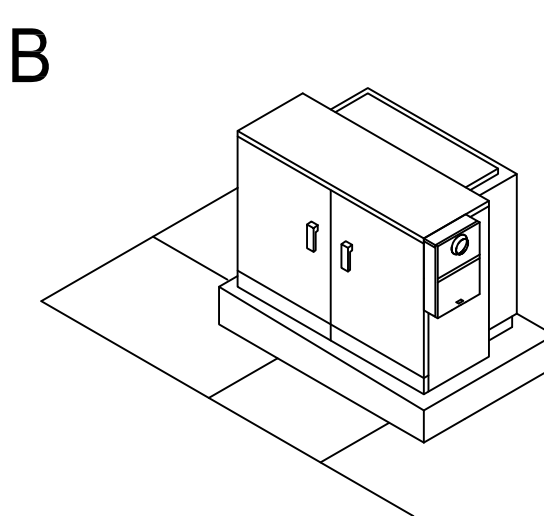
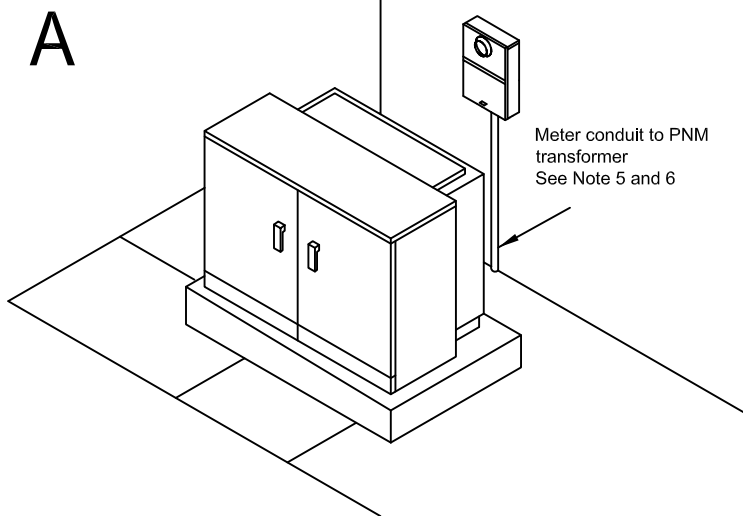

**C** Important:  
Socket shall be wired phase 1-2-3 from left to right and the conductors marked as such. Each conductor phase will be identified at the weather head or padmount, and at the meter base using band-wraps of electrical tape:

- One band for phase one
- Two bands for phase two
- Three bands for phase three
- White tape is suitable for neutral conductors only

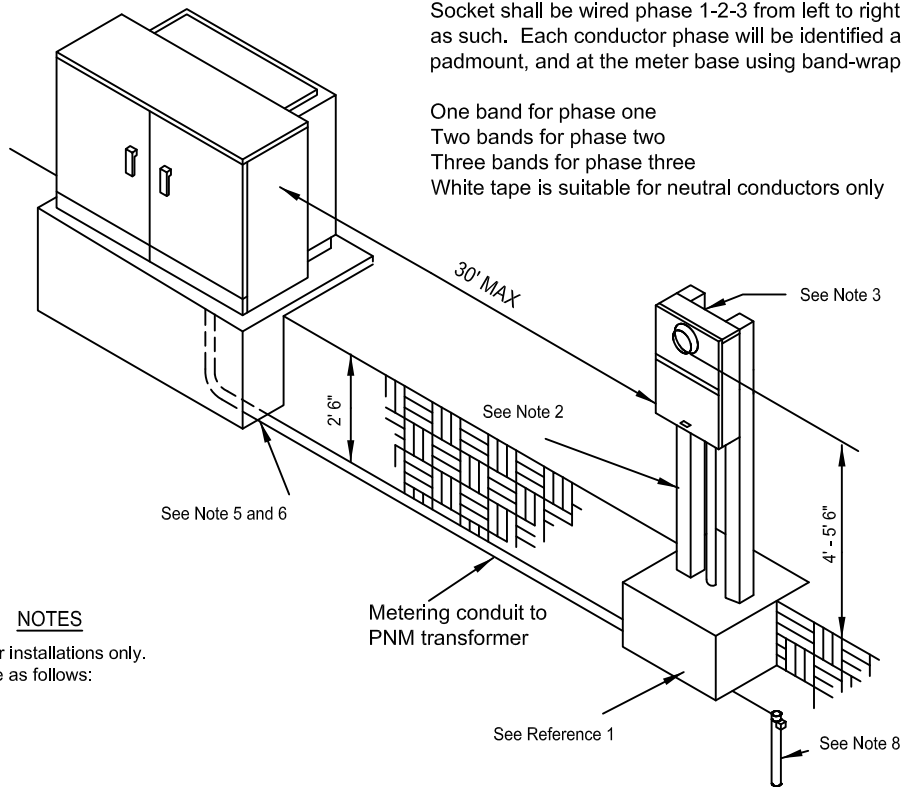

NOTES

- (1) For use on dedicated transformer installations only.
- (2) Acceptable support members are as follows:  
3" x 3" 1/2" angle  
3" x 4.1 lbs/ft channel  
2" x 2" 3/16" box steel  
2 1/2" standard pipe  
P1001 unistrut
- (3) Equipment shall be securely attached to support members either bolted directly or mounted to metal channel or unistrut cross members.
- (4) Contact PNM new customer service representative to assure proper location.
- (5) The conduit must be 1" rigid galvanized.
- (6) Conduit must be buried a minimum 24" and stubbed into transformer secondary compartment. Arrangement with PNM is necessary to open transformer.
- (7) Caution: 2' 6" depth should not be exceeded because of power and telephone cables below.
- (8) Minimum #6 cu ground wire. Connector and rod per NEC article 250. A separate copper grounding electrode conductor sized in accordance with NEC table 250-94 must be provided for connection to PNM's transformer.
- (9) 480V being installed in the Southern Divisions, PT's will be required. See Approved Equipment for approved enclosure. ONLY Options A or C will be used.
- (10) 1-2-3 to be identified in RED, Neutral in WHITE. For Delta services the third (wild) leg in ORANGE.  
Leave wire rolled up in CT can and ensure the wire is long enough to reach Main Disconnect Panel (MDP)

REFERENCES

- (1) See MS-2-7.0 Three-Phase Thirteen-Terminal Socket for CT Meter
- (2) See MS-5-3.0 Single-Phase or Three-Phase Pedestal Meter

**NO  
TEMPORARY  
SERVICE**

Approved Equipment		
Manufacturer	Item	Mfg Part #
B-Line	Enclosure	303011RTCT
Milbank	Enclosure/Panel	363612-CT3R/A-36P36
Pentair/Hoffman	Enclosure	A303012CTCJ

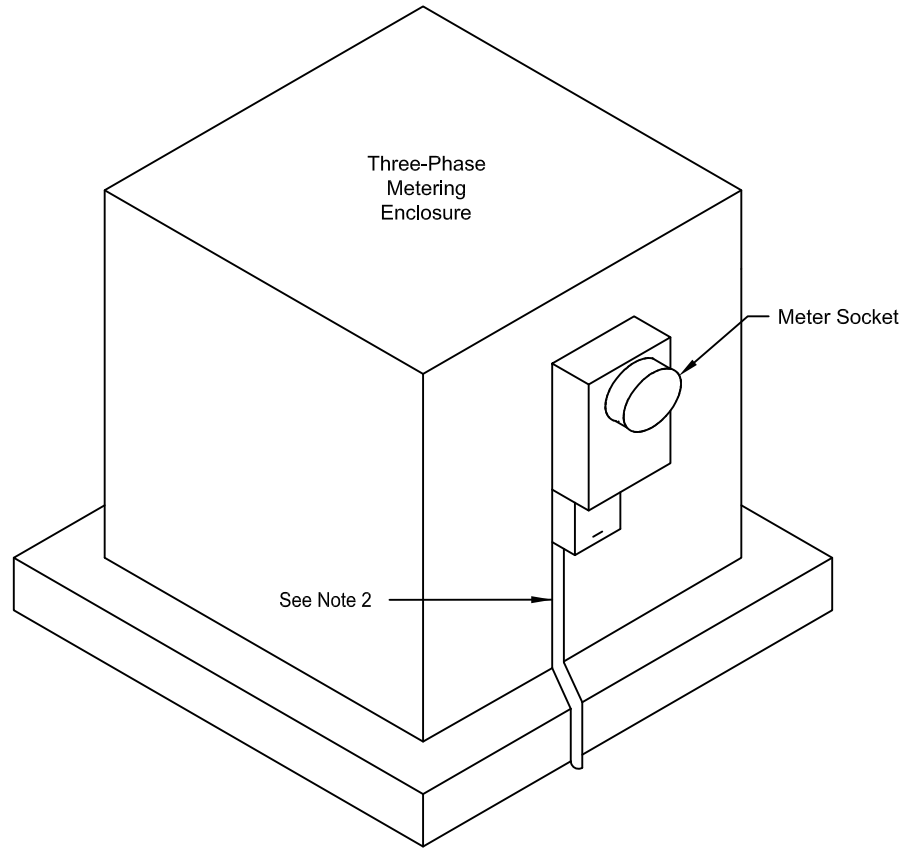

NOTES

- (1) PNM will supply weatherproof lockable junction box and terminal strip for KYZ pulses or modems.
- (2) Customer will provide all conduit (1" maximum diameter) and wiring for his side of the terminal strip and box. Access to the box shall be under customer control. Customer will be responsible for providing a lock for the box and locking it. Conduit must be installed outside of meter enclosure pad.
- (3) Please note, there is a charge for this option.
- (4) PNM equipment will not be accessible to customer.

TERMINAL STRIP FOR KYZ PULSES

- (1) PNM will supply a Form C dry contact isolation relay. The pulses per hour received by the customer's equipment will not exceed 7,200 per hour. The contact rating is 100VA at 100V DC or 120V AC at 1/4A maximum. Customer will provide AC power for their equipment.

TELEPHONE MODEM

- (1) PNM will supply a Hayes-compatible telephone modem internal to the meter.
- (2) Customer access to the modem will be through an RJ11 telephone termination in the junction box.
- (3) Customer will arrange for and pay for telephone line installation. This line will be exclusively used for communication with the meter.
- (4) Customer will pay monthly telephone charges.
- (5) Customer is responsible for telephone line maintenance.
- (6) Customer will provide PNM access to the phone line to interrogate the meter at no charge to PNM.

REFERENCES

- (1) See MS-2-7.0 Three-Phase Thirteen-Terminal Socket for CT Meter
- (2) See MS-3-11.0 120/208-277/480V CT Meter Enclosure

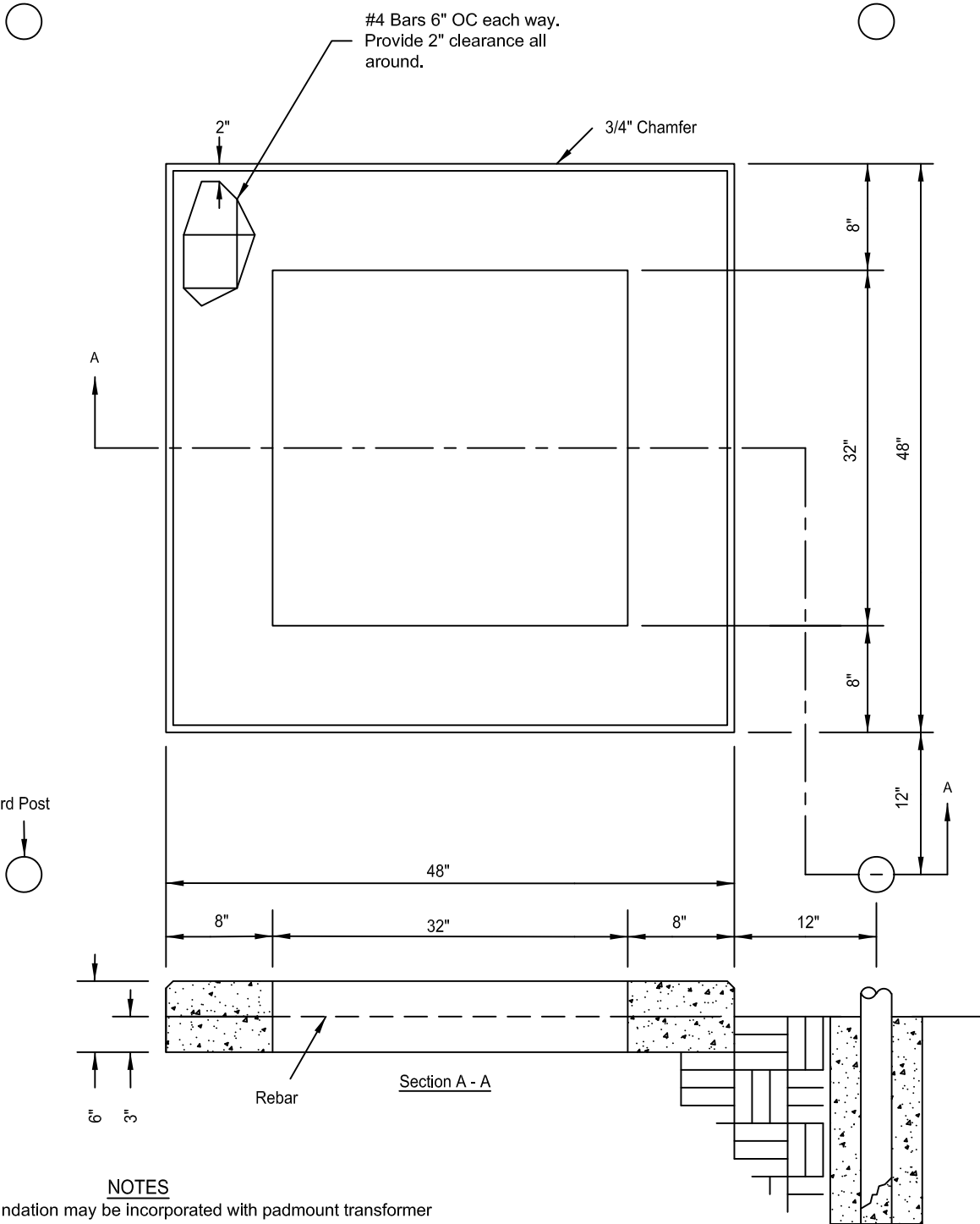

**NOTES**

- (1) Enclosure foundation may be incorporated with padmount transformer foundation.
- (2) Guard posts are required in traffic areas.
- (3) Concrete pad shall be 3000 psi concrete level within  $\pm 1/4"$  in 5' and trowel finished to provide a true plane within  $1/16"$  in 5' as determined by 5' straight edge.
- (4) Existing grade and backfill under concrete pad shall be compacted to 95% in accordance with ASTM D1557.

**REFERENCES**

- (1) See DS-7-16.10 Guard Post
- (2) See MS-3-13.0 120/208-277/480V Transformer and Meter Enclosure Using Conduit
- (3) See MS-7-2.0 Working Space Required for Meter Enclosure

**Maintenance Only**

120/208-277/480V Enclosure Pad

MS-3-16.0

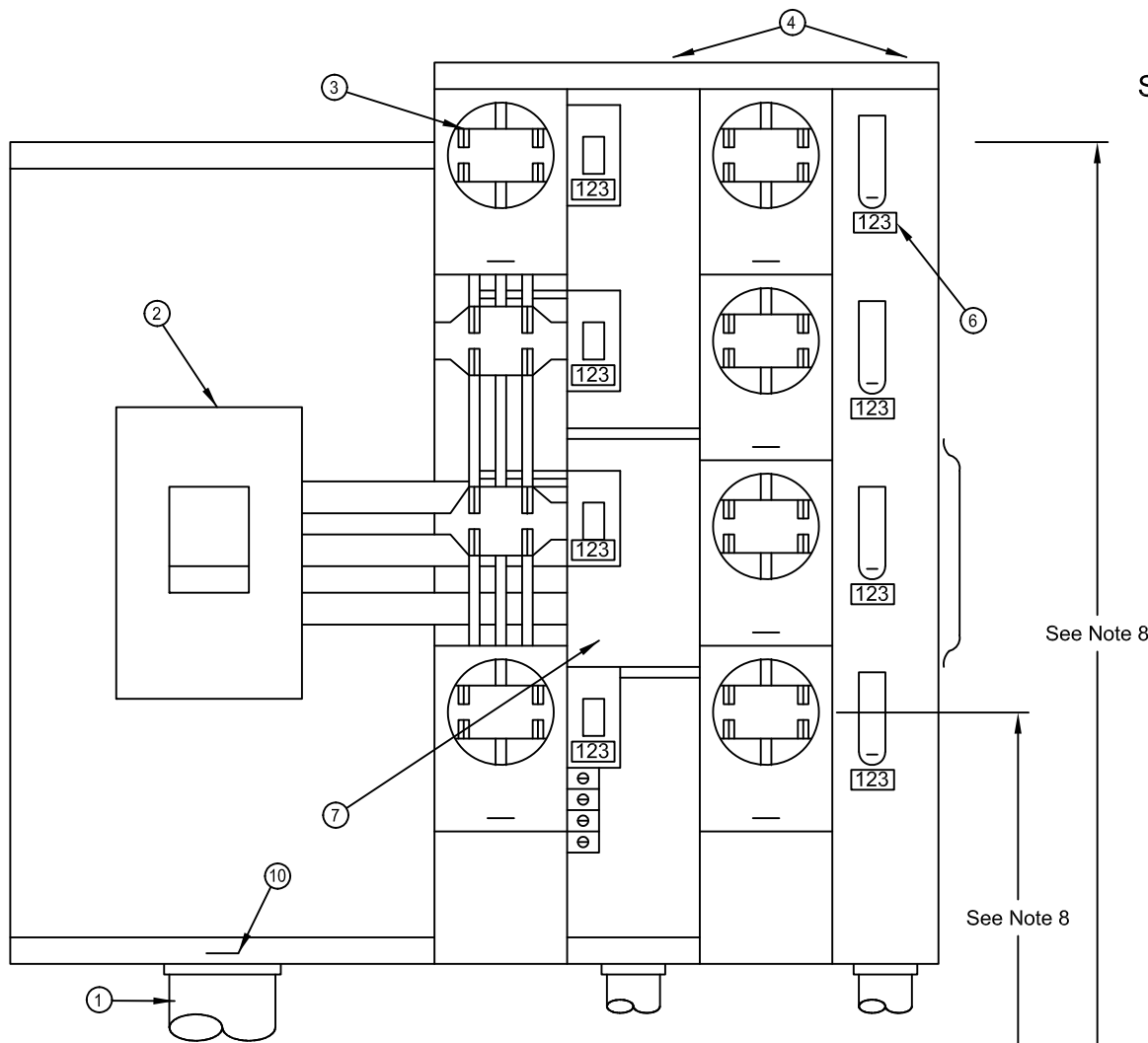

**NOTES**

- (1) Line duct must be rigid galvanized, Schedule 80 PVC or IMC. Coordinate size and number of line duct with PNM.
- (2) Main disconnect may be required on the line side of any group of more than six meter sets to meet NEC, state or local codes.
- (3) New socket jaws installations must be minimum of 200A, for gang meter sockets only. For existing installations 125A is permitted.
- (4) Load conductors may exit either top or bottom of tenant breaker section. They shall not travel through or exit out of socket sections of modules.
- (5) All enclosures shall be securely mounted to building.
- (6) 1" placards to be used under main disconnect and adjacent to the corresponding socket on a non-removable part of the cabinet. No painted or written identification will be accepted.
- (7) Line bus feed must have metal barrier when passing through tenant breaker section for safety and security.
- (8) Top meter shall be a maximum of 79" from finished grade. Bottom meter shall be a minimum of 30" from finish grade. Maximum of four meters per column.
- (9) PNM requires a minimum clearance of 36" minimum between front of sockets and any wall or obstruction.
- (10) All line feed sections shall be lockable and sealable by PNM.
- (11) All units shall be complete with sockets and breakers at the time of initial set of first meter.
- (12) The single-phase house meter must be a four-jaw meter socket with a bypass handle. House meter must be tapped off from the phases and neutral of the line side meter pack main buss or disconnect breaker only when applicable.

**REFERENCES**

- (1) See DM-4-11.0 Maximum Available Fault Currents
- (2) See DS-7-16.10 Guard Post
- (3) See MS-2-1.0 Meter Socket Ring
- (4) See MS-2-2.0 120/240V 125/200A Permanent Single-Phase Meter Socket
- (5) See MS-2-5.0 120/240V 200A Single-Phase Meter Socket with Bypass Handle

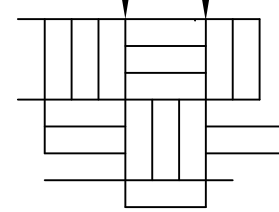

Approved Equipment		
Manufacturer	Item	Mfg Part #
Eaton	200A OH/UG Ringless # Position	1MM***
Eaton	200A OH/UG Ringless # Position	1MP***
Eaton	200A OH/UG Ringless # Position	3MM***
Eaton	200A OH/UG Ringless # Position	35MM***
Eaton	200A OH/UG Ringless # Position	37MM***
Siemens	200A OH/UG Ringless # Position	WMM***
Siemens	200A OH/UG Ringless # Position	WML*****
Siemens	200A OH/UG Ringless	WP2211RJ
Square D	200A OH/UG Ringless # Position	MPR****
Square D	200A OH/UG Ringless Bypass # Pos	MPL****
Square D	200A OH/UG Ringless Bypass # Pos	EZML*****
Square D	200A OH/UG Ringless Bypass	MPH22125
Square D	200A OH/UG Ringless Bypass	MPH44125

\*\*\* There are various catalog # available for # positions.  
Remove the first "W" if units are indoor.

For ease of checking service without interruption, PNM will no longer allow ring meter sockets as of 12/01/2013.

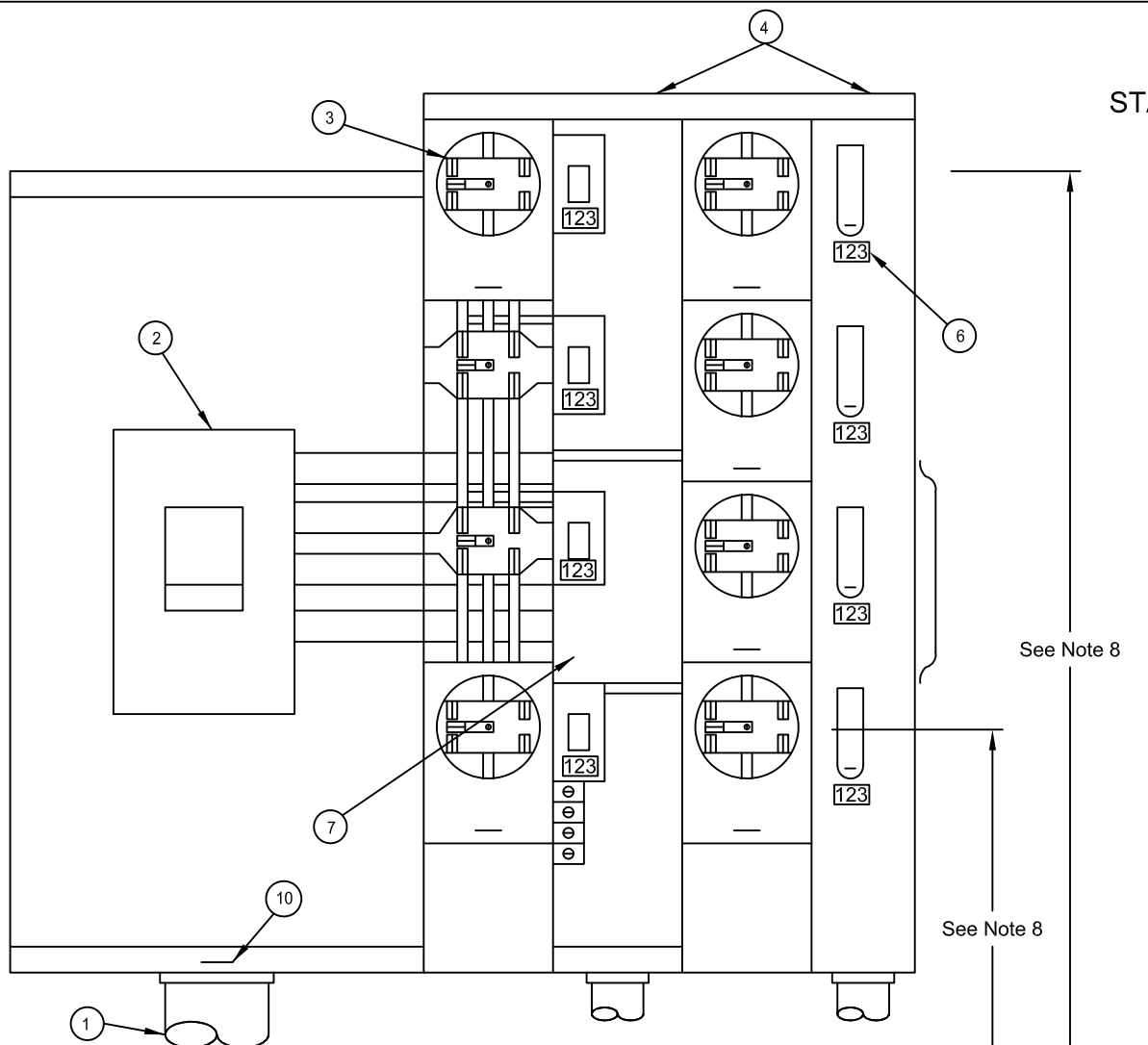

**NOTES**

- (1) Line duct must be rigid galvanized, Schedule 80 PVC or IMC. Coordinate size and number of line ducts with PNM.
- (2) Main disconnect may be required on the line side of any group of more than six meter sets to meet NEC, state or local codes.
- (3) New socket jaws installation must be minimum of 200A for gang meter sockets only. Fifth terminal to be in 9:00 o'clock position. For existing installations 125A is permitted.
- (4) Load conductors may exit either top or bottom of tenant breaker section. They shall not travel through or exit out of socket sections of modules.
- (5) Three-phase services will not be added to this gear after initial installation unless gear was designed and manufactured for that use and approved by PNM.
- (6) 1" placards to be used under main disconnect and adjacent to the corresponding socket on a non-removable part of the cabinet. No painted or written identification will be accepted.
- (7) Line bus feed must have metal barrier when passing through tenant breaker section for safety and security.
- (8) Top meter shall be a maximum of 79" from finished grade. Bottom meter shall be a minimum of 30" from finish grade. Maximum of four meters per column.
- (9) PNM requires a minimum clearance of 36" minimum between front of sockets and any wall or obstruction.
- (10) All line feed sections shall be lockable and sealable by PNM.
- (11) All units shall be complete with sockets and breakers at the time of initial set of first meter.
- (12) Guard posts will be required in traffic areas.
- (13) The three-phase house meter must be a seven-jaw with bypass handle. House meter must be tapped off from all phases and neutral of the line side meter pack main buss or disconnect.

**REFERENCES**

- (1) See DM-4-11.0 Maximum Available Fault Currents
- (2) See DS-7-16.10 Guard Post
- (3) See MS-2-1.0 Meter Socket Ring
- (4) See MS-2-6.0 120/208 Wye or 120/240 Delta 200A Three-Phase Four-Wire Wye or Delta Meter Socket with Bypass

**RESIDENTIAL  
USE  
ONLY**

Approved Equipment		
Manufacturer	Item	Mfg Part #
Eaton	200A OH/UG Ringless # Position	1MM***
Eaton	200A OH/UG Ringless # Position	1MP***
Eaton	200A OH/UG Ringless # Position	3MM****
Eaton	200A OH/UG Ringless # Position	35MM****
Eaton	200A OH/UG Ringless # Position	37MM****
GE	200A OH/UG Ringless # Position	TMP8420R
GE	200A OH/UG Ringless # Position	TMP12020R
Siemens	200A OH/UG Ringless # Position	WMM****
Siemens	200A OH/UG Ringless # Position	WML*****
Square D	200A OH/UG Ringless # Position	MPR****

\*\*\*There are various catalog # available for # positions.

Remove the first "W" if units are indoor

For ease of checking service without interruption, PNM will no longer allow ring meter sockets as of 12/01/2013.

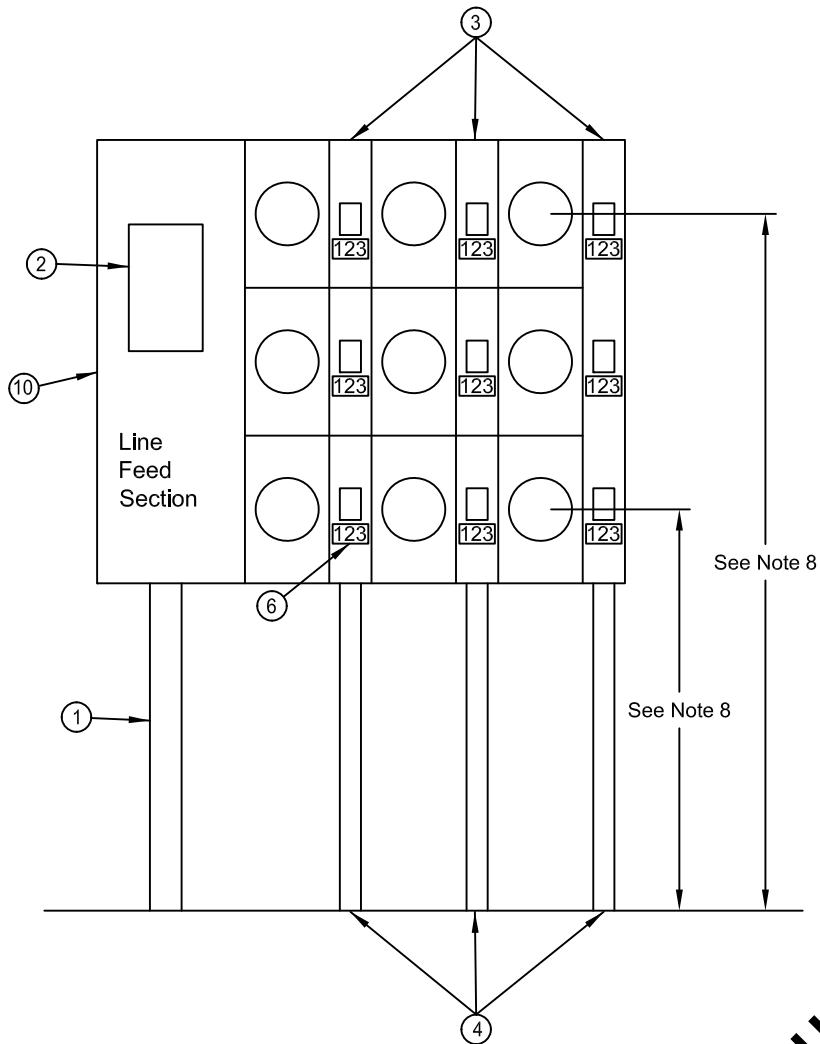

**NOTES**

- (1) Line conduit must be rigid galvanized, Schedule 80 PVC or IMC. Coordinate size and number of line conduits with PNM.
- (2) Main disconnect may be required on the line side of any group of more than six meter sets to meet NEC, state or local codes.
- (3) All units shall be complete with sockets and breakers at the time of initial set of first meter.
- (4) Load conductors may exit either top or bottom of tenant breaker section. They shall not travel through or exit out of socket sections of modules.
- (5) All enclosures shall be securely mounted to building.
- (6) 1" placards to be used under main disconnect and adjacent to the corresponding socket on a non-removable part of the cabinet. No painted or written identification will be accepted.
- (7) Guard posts will be required in traffic areas.
- (8) Top meter shall be a maximum of 79" from finished grade. Bottom meter shall be a minimum of 30" from finish grade. Maximum of four meters per column.
- (9) PNM requires a minimum clearance of 36" minimum between front of sockets and any wall or obstruction.
- (10) All line feed sections shall be lockable and sealable by PNM.
- (11) All units shall be complete with sockets and breakers at the time of initial set of first meter.

**REFERENCES**

- (1) See DM-4-11.0 Maximum Available Fault Currents
- (2) See DS-7-16.10 Guard Post
- (3) See MS-2-6.0 120/208 Wye or 120/240 Delta 200A Three-Phase Four-Wire Wye or Delta Meter Socket with Bypass

**Important:**

Socket shall be wired phase 1-2-3 from left to right and the conductors marked as such. Each conductor phase will be identified at the weather head or padmount, and at the meter base using band-wraps of electrical tape:

- One band for phase one
- Two bands for phase two
- Three bands for phase three
- White tape is suitable for neutral conductors only.

Approved Equipment		
Manufacturer	Item	Mfg Part #
Siemens	200A OH/UG Ringless # Position	WPL4*12RJ
Siemens	200A OH/UG Ringless # Position, 600A Buss	WPL6612RJ
Siemens	200A OH/UG Ringless # Position, 800A Buss	WPL8612RJ
Siemens	200A OH/UG Ringless # Position, 1000A Buss	WPL10612RJ
Square D	200A OH/UG Ringless * Position	EZML33*225

\* There are various catalog#s available for # of positions

For ease of checking service without interruption, PNM will no longer allow ring meter sockets as of 12/01/2013.

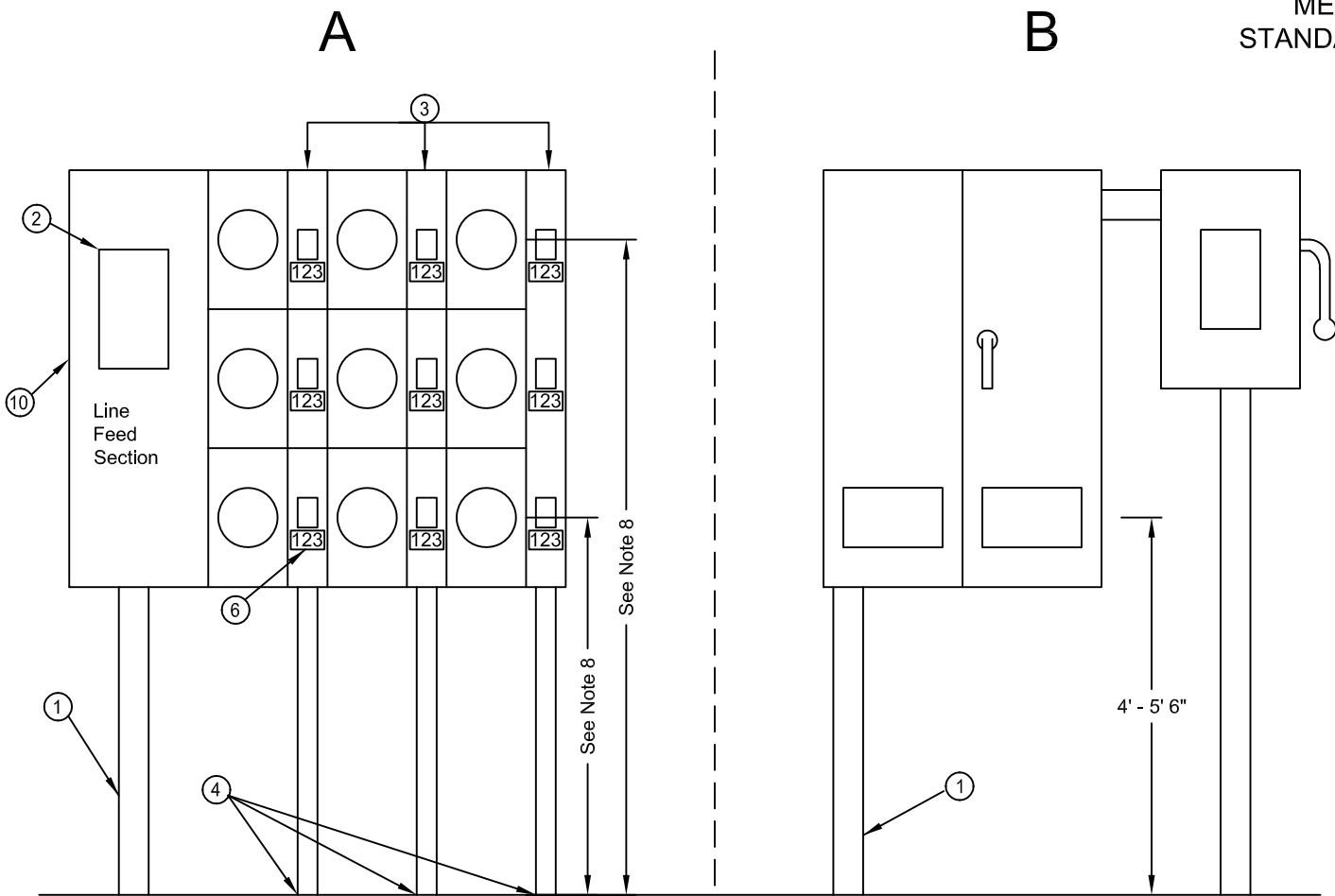

**NOTES**

- (1) Line conduit must be rigid galvanized, Schedule 80 PVC or IMC. Coordinate size and number of line conduits with PNM.
- (2) Main disconnect may be required on the line side of any group of more than six meter sets to meet NEC, state or local codes.
- (3) All units shall be complete with sockets and breakers at the time of initial set of first meter.
- (4) Load conductors may exit either top or bottom of tenant breaker section. They shall not travel through or exit out of socket sections of modules.
- (5) All enclosures shall be securely mounted to building.
- (6) 1" placards to be used under main disconnect and adjacent to the corresponding socket on a non-removable part of the cabinet. No painted or written identification will be accepted.
- (7) Guard posts will be required in traffic areas.
- (8) Top meter shall be a maximum of 79" from finished grade. Bottom meter shall be a minimum of 30" from finish grade. Maximum of four meters per column.
- (9) PNM requires a minimum clearance of 36" minimum between front of sockets and any wall or obstruction.
- (10) All line feed sections shall be lockable and sealable by PNM.
- (11) All units shall be complete with sockets and breakers at the time of initial set of first meter.
- (12) "A" is for metering 120/208-277/480V seven-jaw sockets with 200A loads.
- (13) "B" is for metering customer with loads over 200A.

**REFERENCES**

- (1) See DM-4-11.0 Maximum Available Fault Currents
- (2) See DS-7-16.10 Guard Post
- (3) See MS-2-6.0 120/208 Wye or 120/240 Delta 200A Three-Phase Four-Wire Wye or Delta Meter Socket wit Bypass
- (4) See MS-3-8.0 Over 200A Three-Phase Meter Options
- (5) See MS-4-8.0 Switchgear Seven-Jaw Socket Meter
- (6) See MS-4-11.0 120/208 or 277/480V Switchgear Metering

**Important:**

Socket shall be wired phase 1-2-3 from left to right and the conductors marked as such. Each conductor phase will be identified at the weather head or padmount, and at the meter base using band-wraps of electrical tape:

- One band for phase one
- Two bands for phase two
- Three bands for phase three
- White tape is suitable for neutral conductors only

Approved Equipment		
Manufacturer	Item	Mfg Part #
Square D	200A OH/UG Ringless * Position	EZML33*225

\* There are various catalog #'s available for # of positions

For ease of checking service without interruption, PNM will no longer allow ring meter sockets as of 12/01/2013.

**120/208-277/480V Three-Phase Four-Wire Multiple Meter**

**MS-4-4.0**



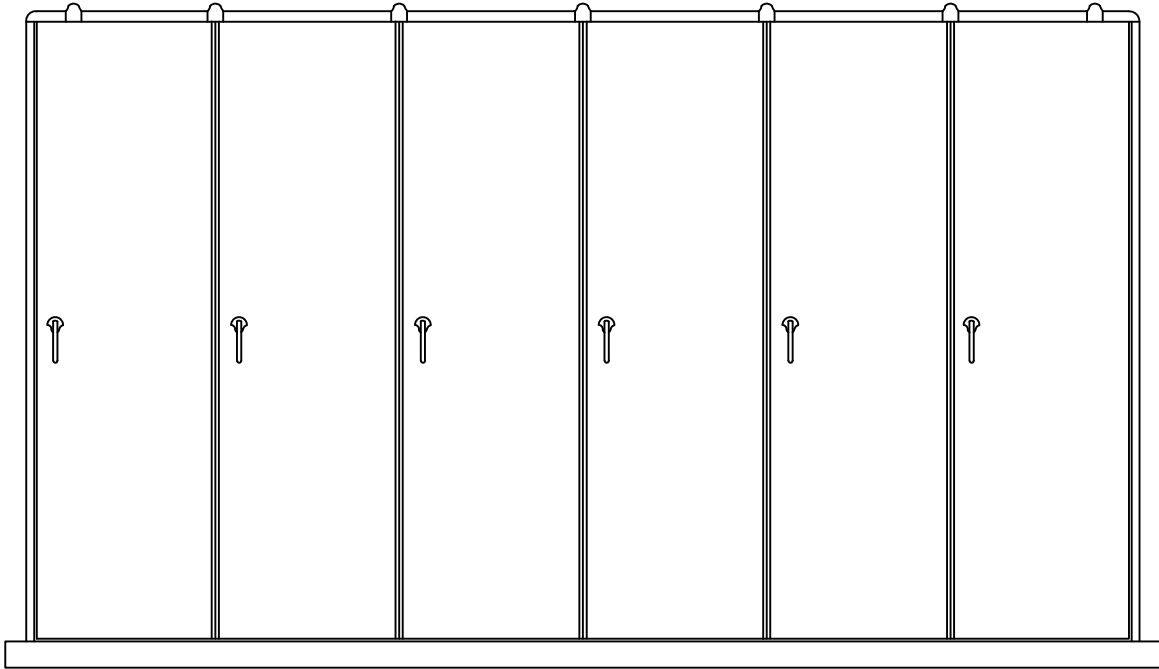

#### NOTES

- (1) This equipment to be used as housing for three-phase 120/208, 277/480V switchgear and metering when used outdoors.
- (2) Drawing must be submitted to meter department for approval.
- (3) Dual locking arrangements must be made. Enclosure door must be operable without the use of tools.
- (4) Customer building number must be permanently painted under main disconnect.
- (5) Same spacing can be used for various metering application.
- (6) Guard posts will be required in traffic areas.

#### REFERENCES

- (1) See DS-7-16.10 Guard Post
- (2) See MS-4-11.0 120/208 or 277/480V Switchgear Metering

Rain Tight Housing for Switchgear and Meter

MS-4-5.0

Top View

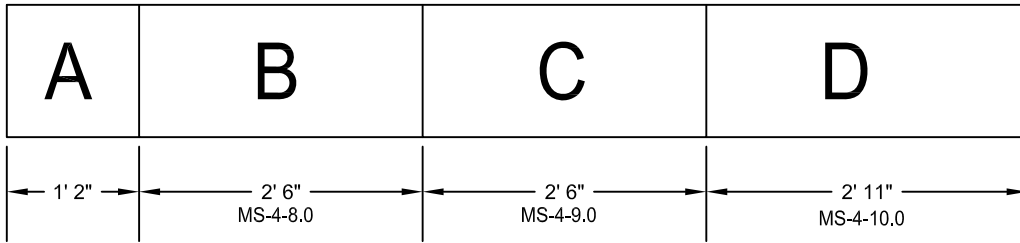

Front View

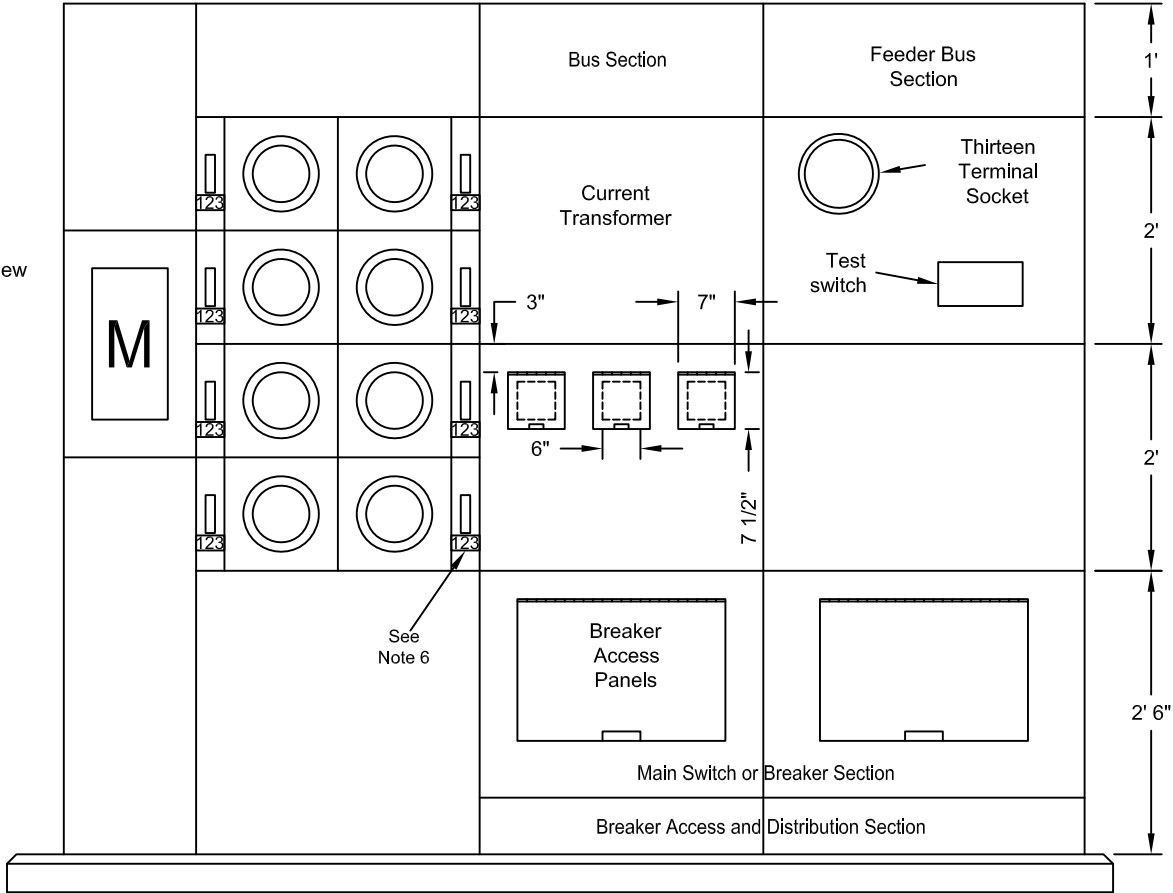

NOTES

- (1) "A" is a pull section for cables from the padmount transformer. This section could be at either end of switchgear. Main disconnect could be required to meet NEC, state or local codes. Load conductors shall not be allowed in this or bus sections of switchgear.
- (2) "B" 200A seven-jaw sockets.
- (3) "C" is for metering customers with CT's 800A and under.
- (4) "D" is for metering customers with CT's 800A and over.
- (5) Front panels must be removable and sealable.
- (6) 1" placards to be used under main disconnect and adjacent to the corresponding socket on a non-removable part of the cabinet. No painted or written identification will be accepted.
- (7) Rain tight housing should be used if switch gear is in unprotected location.

Important:

Socket shall be wired phase 1-2-3 from left to right and the conductors marked as such. Each conductor phase will be identified at the weather head or padmount, and at the meter base using band-wraps of electrical tape:

- One band for phase one
- Two bands for phase two
- Three bands for phase three
- White tape is suitable for neutral conductors only

REFERENCES

- (1) See DM-4-11.0 Maximum Available Fault Currents
- (2) See MS-4-5.0 Raintight Housing for Switchgear and Meter
- (3) See MS-4-8.0 Seven-Jaw Socket Switchgear Meter
- (4) See MS-4-9.0 Cradle Mount CT Switchgear Metering
- (5) See MS-4-10.0 Base Mount CT Switchgear Metering

**MAINTENANCE  
ONLY**

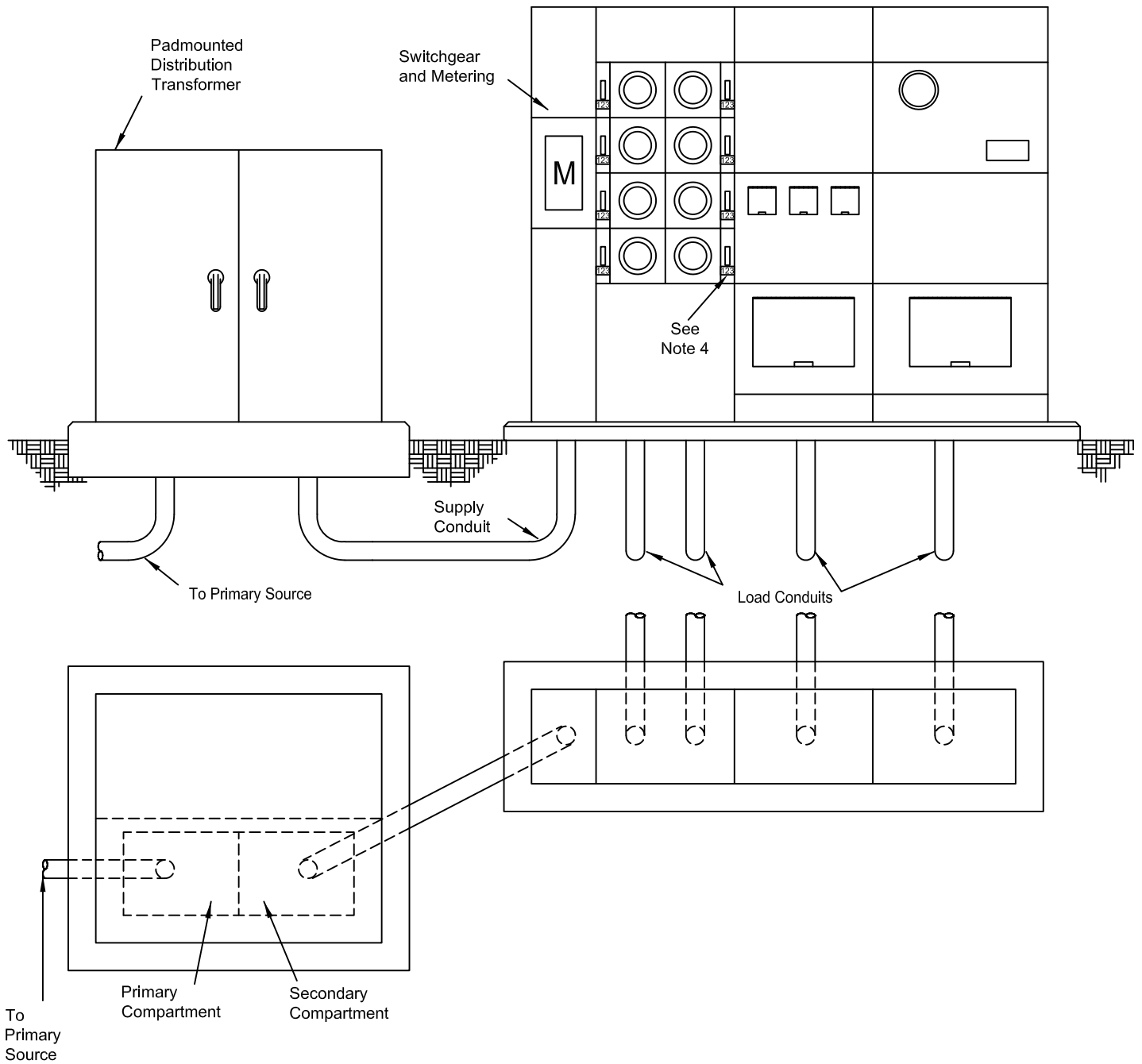

**NOTES**

- (1) Rain tight housing should be used if switchgear is mounted in unprotected location.
- (2) Switchgear and transformer may be mounted on common pad.
- (3) Guard posts will be required in traffic areas.
- (4) 1" placards to be used under main disconnect and adjacent to the corresponding socket on a non-removable part of the cabinet. No painted or written identification will be accepted.

**REFERENCES**

- (1) See Section 7 for individual pad details
- (2) See DS-7-16.10 Guard Post
- (3) See MS-4-5.0 Raintight Housing for Switchgear and Meter
- (4) See MS-4-8.0 Switchgear Seven-jaw Socket Meter
- (5) See MS-4-9.0 Cradle Mount CT Switchgear Metering
- (6) See MS-4-10.0 Base Mount CT Switchgear Metering

**Important:**

Socket shall be wired phase 1-2-3 from left to right and the conductors marked as such. Each conductor phase will be identified at the weather head or padmount, and at the meter base using band-wraps of electrical tape:

- One band for phase one
- Two bands for phase two
- Three bands for phase three
- White tape is suitable for neutral conductors only

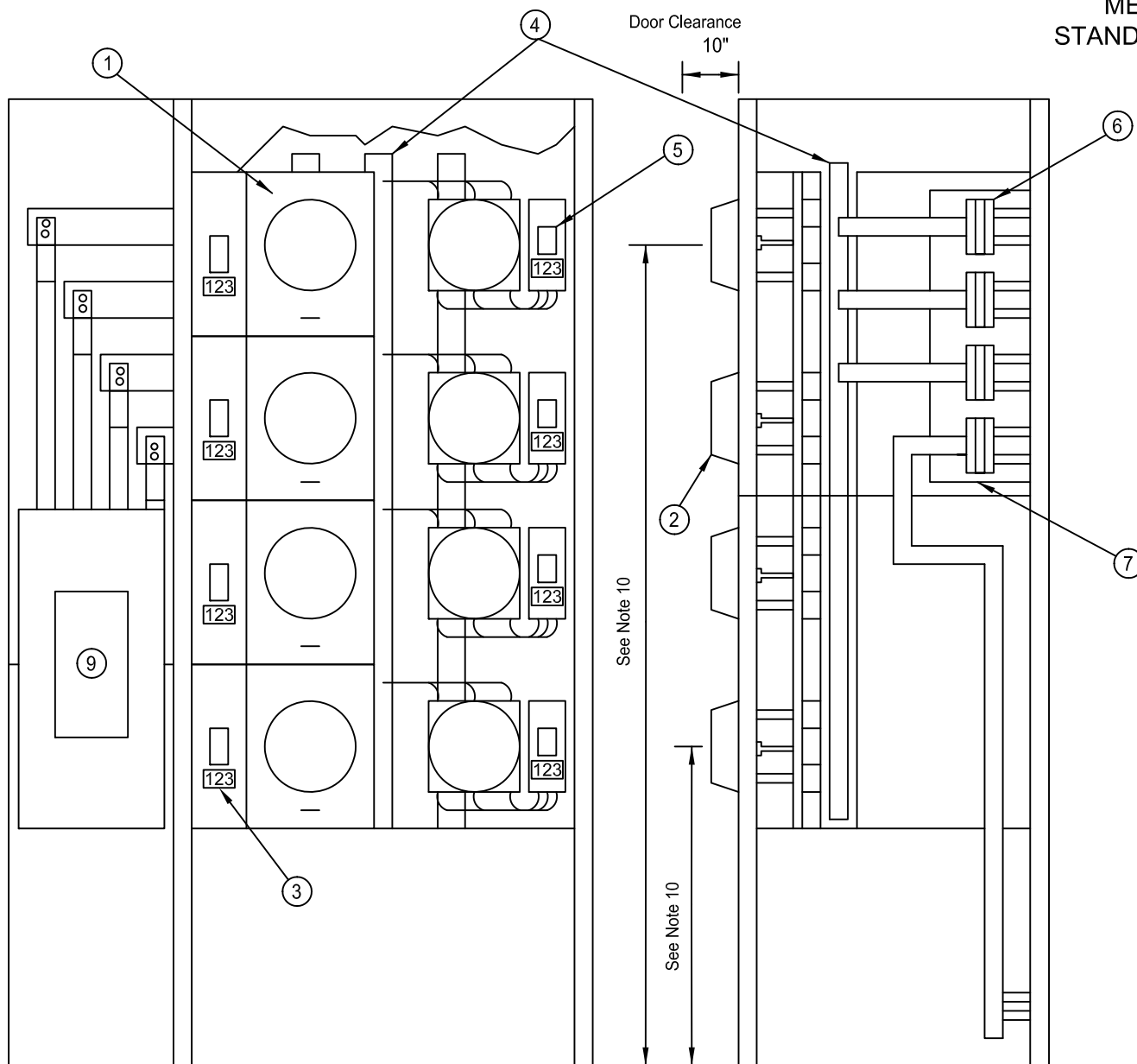

**NOTES**

- (1) Single meter covers with provisions to seal and or lock.
- (2) 120/208V, 277/480V seven-jaw socket, 200A only.
- (3) 1" placards to be used under main disconnect and adjacent to the corresponding socket on a non-removable part of the cabinet. No painted or written identification will be accepted.
- (4) Panel bus
- (5) Circuit breaker
- (6) Cross bus
- (7) Barriers per UL, NEC, AND PNM Requirements.
- (8) Service entrance equipment shall be designed for an available fault current of 60,000A symmetrical three-phase at the transformer.
- (9) Main disconnect may be required on the line side of any group of more than six meter sets to meet NEC, state or local codes.
- (10) Top meter shall be maximum of 79" from finish grade. Bottom meter shall be a minimum of 30" from finish grade. Maximum of four meters per column.
- (11) All units shall be complete with sockets and breakers at the time of the initial set of first meter.
- (12) Guard posts will be required

**REFERENCES**

- (1) See DM-4-11.0 Maximum Available Fault Currents
- (2) See DS-7-16.10 Guard post
- (3) See MS-2-6.0 120/208 Wye or 120/240 Delta 200A Three-Phase Four-Wire Wye or Delta Meter Socket with Bypass
- (4) See MS-4-9.0 Cradle Mount CT Switchgear Metering

**Important:**

Socket shall be wired phase 1-2-3 from left to right and the conductors marked as such. Each conductor phase will be identified at the weather head or padmount, and at the meter base using band-wraps of electrical tape:

- One band for phase one
- Two bands for phase two
- Three bands for phase three
- White tape is suitable for neutral conductors only

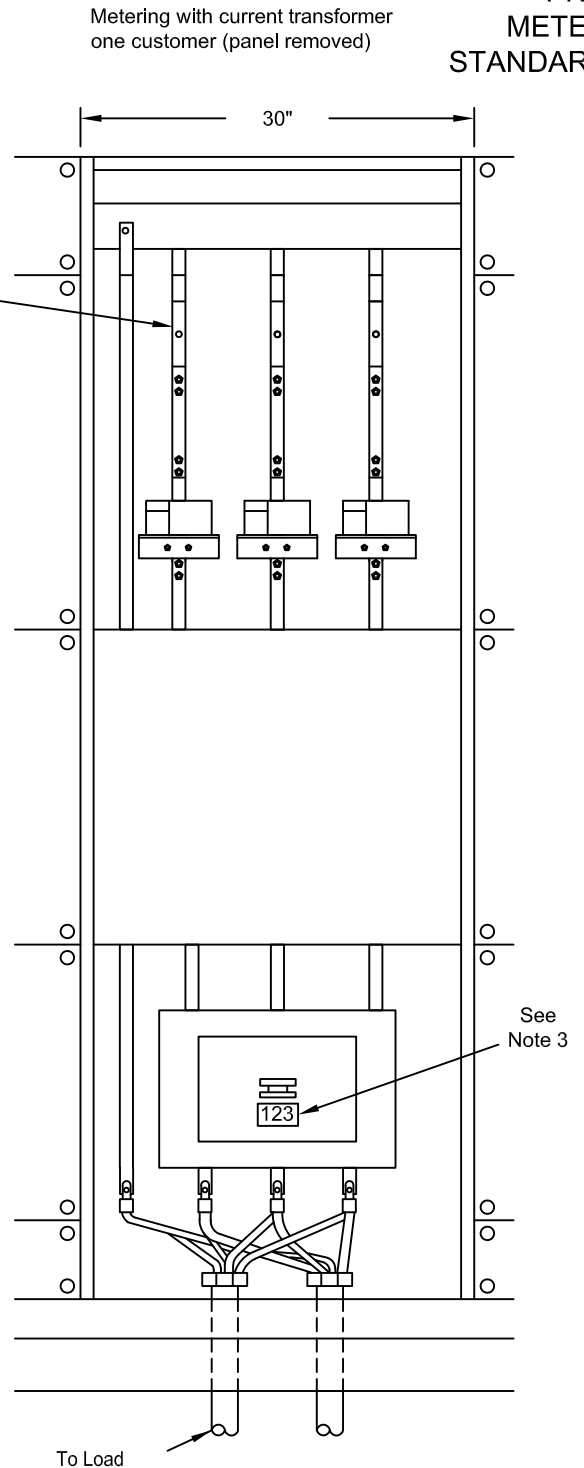
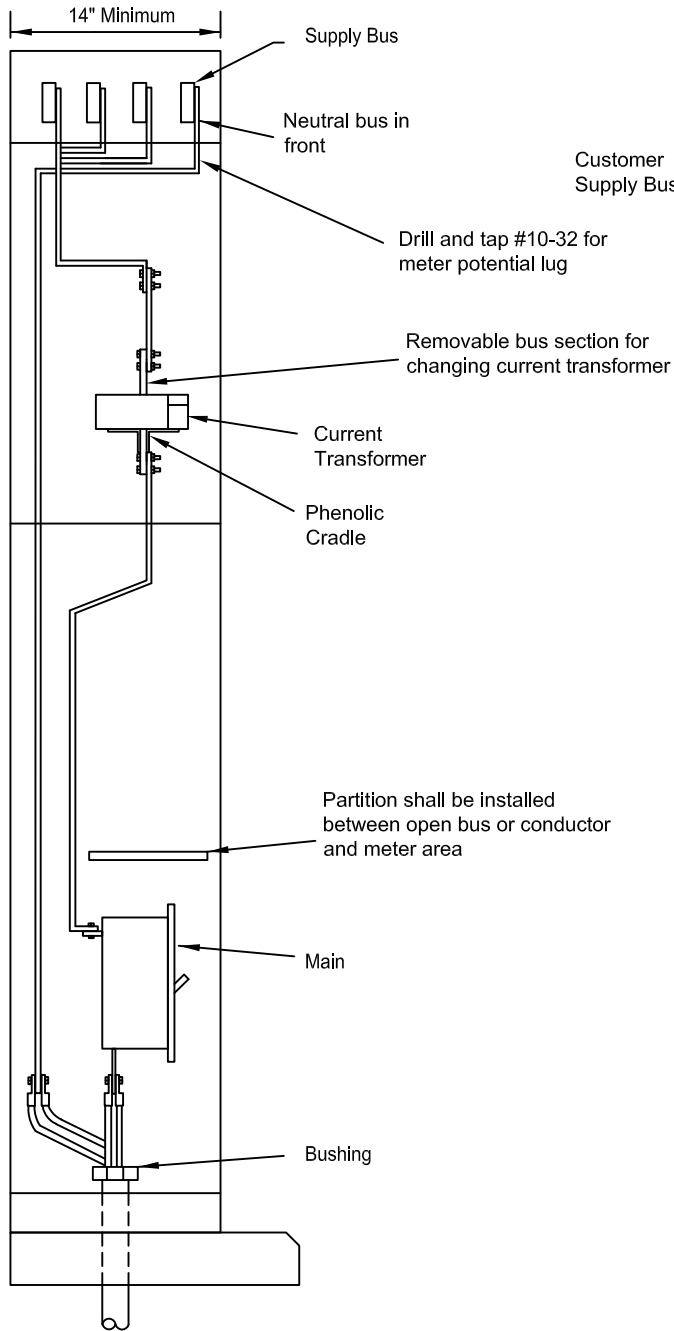

**NOTES**

- (1) Bond neutral bus, cabinet and meter bases to common ground.
- (2) Bond CT secondary meter frames to cabinet and neutral bus.
- (3) 1" placards to be used under main disconnect and adjacent to the corresponding socket on a non-removable part of the cabinet. No painted or written identification will be accepted.
- (4) If conductor are used instead of bus, they must be kept behind meter board.
- (5) Load conductors must leave switchgear through bottom area. NEC does not allow load conductors to exit through line bus area.

**REFERENCES**

- (1) See DM-4-11.0 Maximum Available Fault currents
- (2) See DS-7-16.10 Guard post
- (3) See MS-4-6.0 120/208-277/480V Switchgear
- (4) See EUSERC Section 300 Metering and Service Equipment

Metering with Current Transformer  
One Current (Panel Removed)

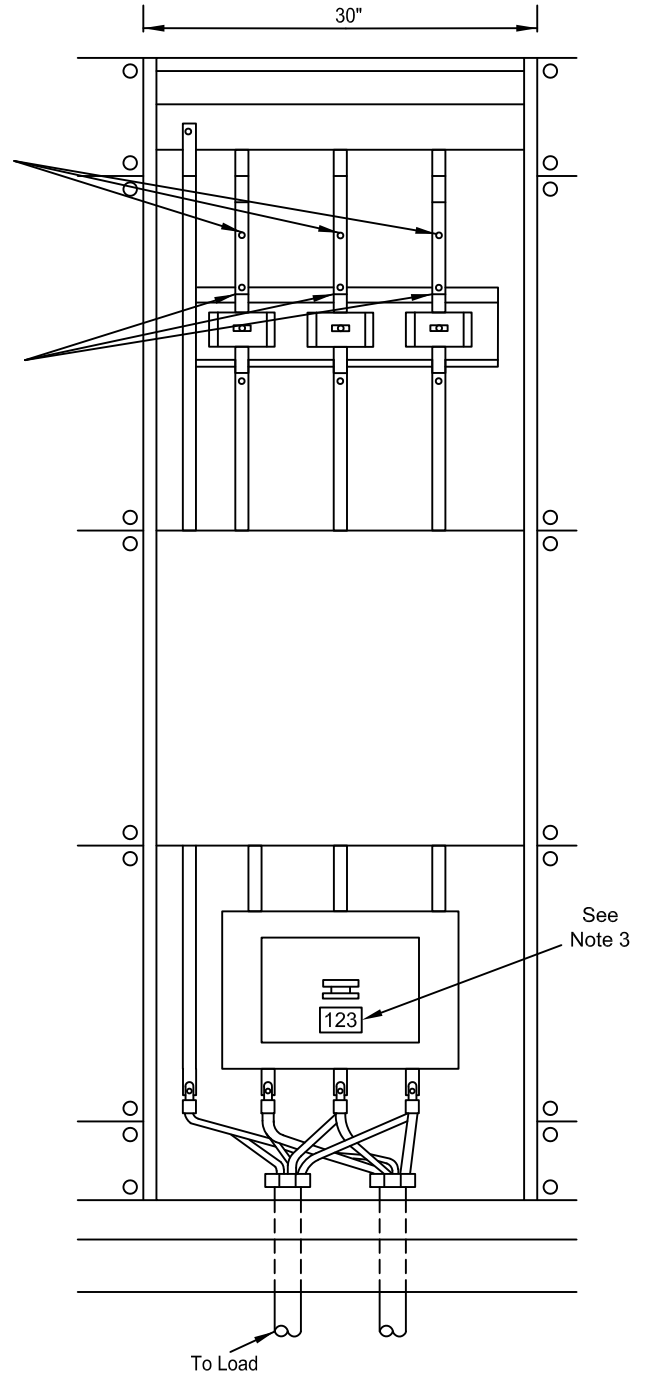
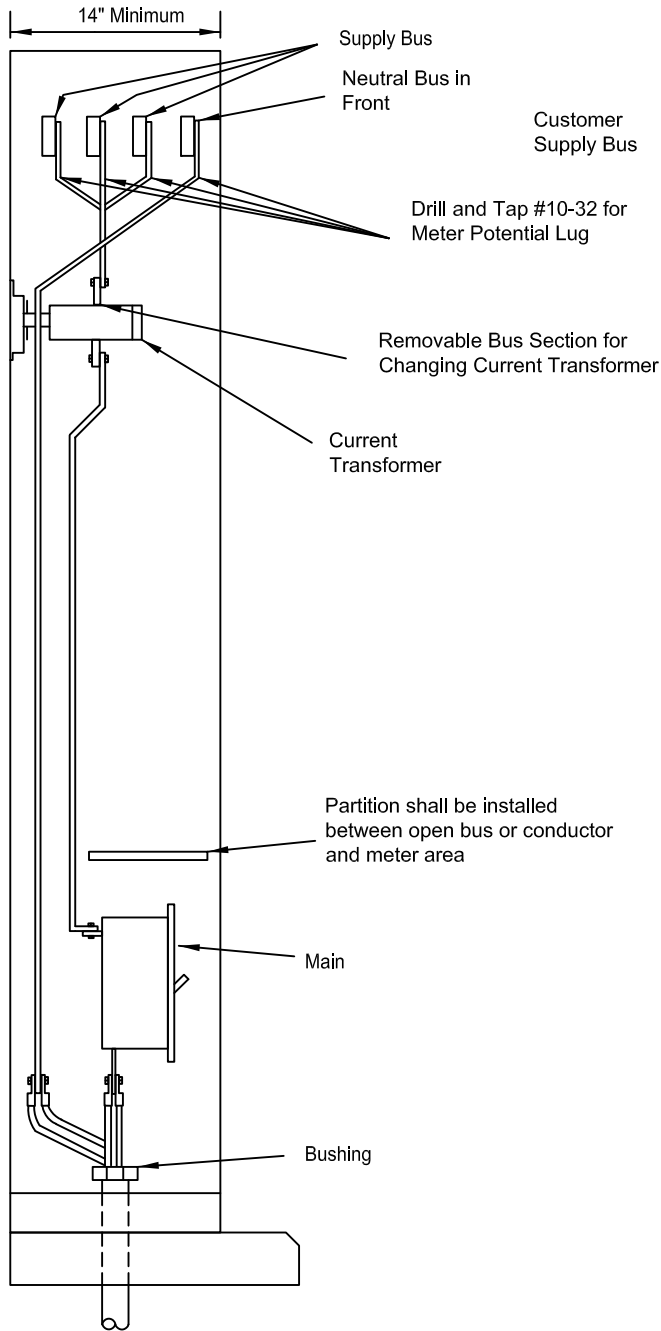

NOTES

- (1) Bond neutral bus, cabinet and meter bases to common ground.
- (2) Bond CT secondary meter frames to cabinet and neutral bus.
- (3) 1" placards to be used under main disconnect and adjacent to the corresponding socket on a non-removable part of the cabinet. No painted or written identification will be accepted.
- (4) If conductors are used instead of bus. They must be kept behind meter board.
- (5) Load conductors must leave switchgear through bottom area. NEC does not allow load conductors to exit through line bus area.

REFERENCES

- (1) See DS-4-11.0 Maximum Available Fault Currents
- (2) See DS-7-16.10 Guard Post
- (3) See MS-4-6.0 120/208-277/480V Switchgear

**MAINTENANCE  
ONLY**

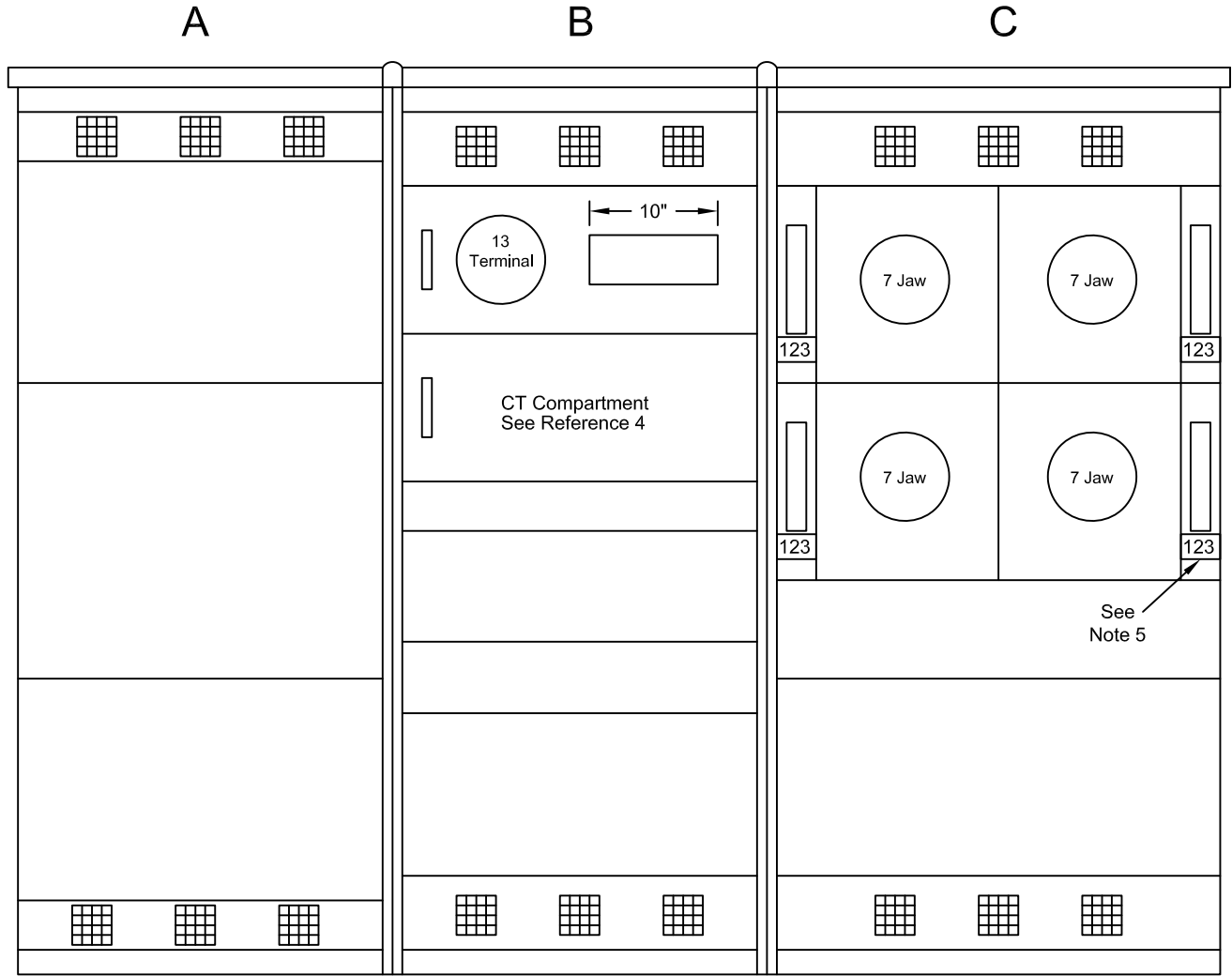

**NOTES**

- (1) "A" is a pull section for cables from the padmount transformer. This section could be at either end of switchgear. Main disconnect could be required to meet NEC, state or local codes. Load conductors shall not be allowed in this or bus sections of switchgear.
- (2) "B" is for metering customers with loads over 200A.
- (3) "C" 200A seven-jaw sockets.
- (4) Front panels must be removable and sealable.
- (5) 1" placards to be used under main disconnect and adjacent to the corresponding socket on a non-removable part of the cabinet. No painted or written identification will be accepted.
- (6) Rain tight housing should be used if switch gear is in unprotected location.
- (7) Switchgear metering must have a lockable load side main disconnect.

**REFERENCES**

- (1) See DM-4-11.0 Maximum Available Fault Currents
- (2) See MS-4-5.0 Raintight Housing for Switchgear and Meter
- (3) See MS-4-8.0 Seven-Jaw Socket Switchgear Meter
- (4) See MS-4-9.0 Cradle Mount CT Switchgear Metering

**Important:**

Socket shall be wired phase 1-2-3 from left to right and the conductors marked as such. Each conductor phase will be identified at the weather head or padmount, and at the meter base using band-wraps of electrical tape:

- One band for phase one
- Two bands for phase two
- Three bands for phase three
- White tape is suitable for neutral conductors only

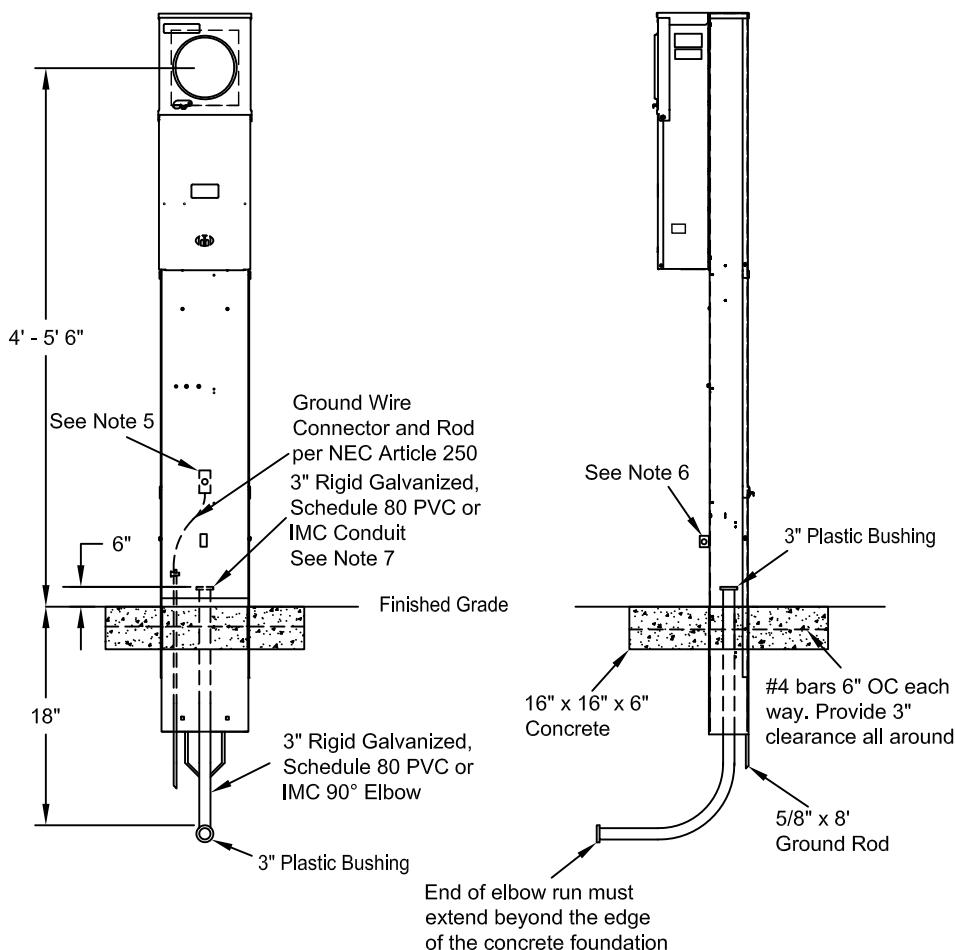

**NOTES**

- (1) Pedestal construction from 14 gauge steel with corrosion resistant finish.
- (2) Meter socket minimum rating 125A factory wired in separate wire way from terminal block to meter socket.
- (3) For services larger than 125A, a factory rated 200 or 320A pedestal must be used.
- (4) Insulated stud terminal block or bus pads to accommodate PNM connections.
- (5) Pedestal bonding lug grounding conductor must be continuous to breaker panel grounding terminal.
- (6) Termination section to have removable rain tight cover with provision for padlocking. All other removable portions of termination section must be sealable.
- (7) Rigid galvanized, schedule 80 PVC or IMC 90° elbow. If plastic conduit is used in place of rigid, it must be encased in 2" of concrete from where it enters metal enclosure, to 18" below ground level. End of elbow conduit run must extend beyond the edge of the concrete foundation.
- (8) Contact your new service representative with the meter location and estimated load for more information.
- (9) Commercial application for non-critical loads, i.e. sprinklers controls and gates. PNM will allow socket without bypass handle.
- (10) Allowed on single manufactured and mobile homes ONLY. For mobile home parks see MS-5-4.0.
- (11) Ground wire connector and rod per NEC Article 250.
- (12) Equipped with lever arm bypass with jaw tension release.

Residential Underground Service Entrance Conduit Size (Internal Diameter)			
Service Distance (ft)	*125A Class Meter Socket	200A Class Meter Socket	320A Class Meter Socket
100' or Less	3.0"	3.0"	3.0"
Greater than 100'	3.0"	3.0"	3.0"

- Contact your new service representative with the meter location and estimated load for more information.
- \*For manufactured and mobile homes ONLY
- Main breaker larger than 320 Amps See MS-3-7.0

Approved Equipment		
Manufacturer	Item	Mfg Part #
Millbank Midwest	200A Ringless Pedestal 200A Ringless Pedestal Residential ONLY	U5136-0-200S U5136-0-200S
Square D	200A Ringless Pedestal	UHTRP242363

For ease of checking service without interruption, PNM will no longer allow ring meter sockets as of 12/01/2013.

**REFERENCES**

- (1) See DM-4-11.0 Maximum Available Fault Currents

120/240V 125 to 200A Rated Socket Pedestal Meter



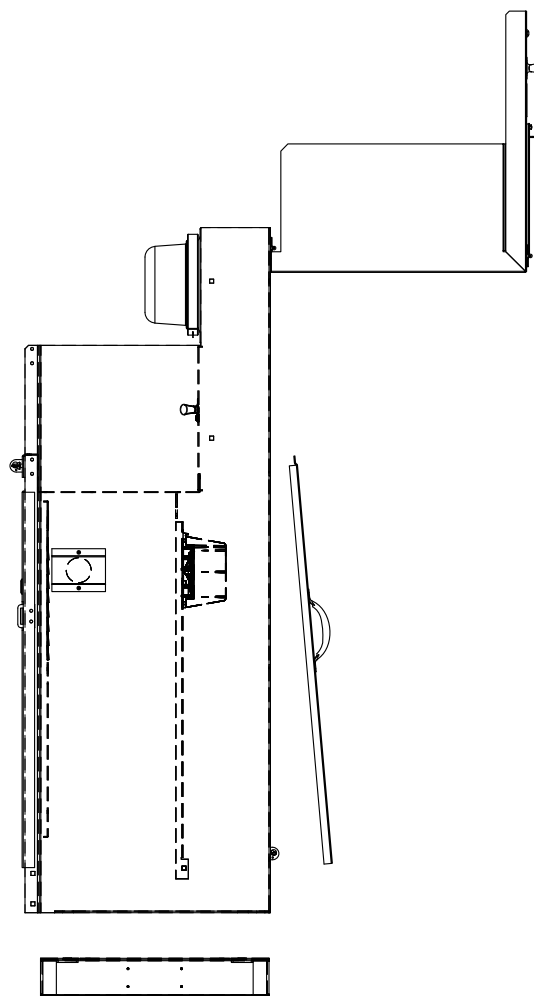
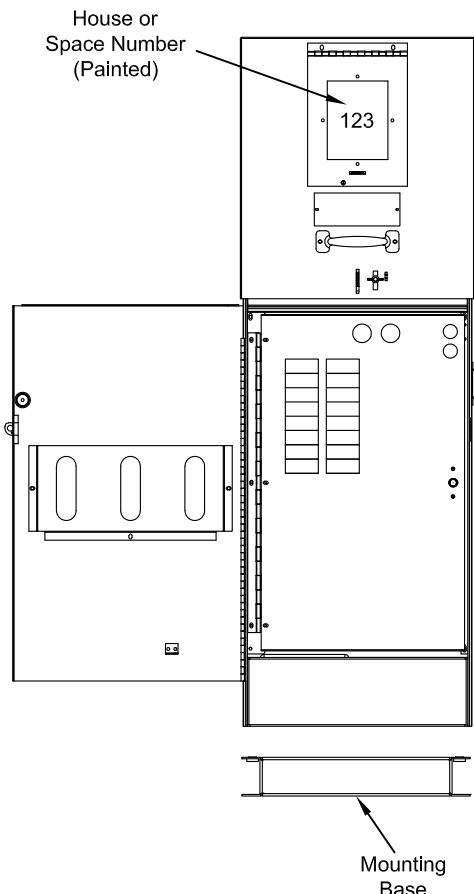

**NOTES**

- (1) Pedestal construction from 14 gauge steel with corrosion resistant finish.
- (2) Meter socket minimum rating 125A factory wired in separate wire way from terminal block to meter socket.
- (3) For services larger than 125A, a factory rated 200 or 320A pedestal must be used.
- (4) Insulated stud terminal block or bus pads to accommodate PNM connections.
- (5) Pedestal bonding lug grounding conductor must be continuous to breaker panel grounding terminal.
- (6) Termination section to have removable rain tight cover with provision for padlocking. All other removable portions of termination section must be sealable.
- (7) Rigid galvanized, schedule 80 PVC or IMC 90° elbow. If plastic conduit is used in place of rigid, it must be encased in 2" of concrete from where it enters metal enclosure, to 18" below ground level. End of elbow conduit run must extend beyond the edge of the concrete foundation.
- (8) Contact your new service representative with the meter location and estimated load for more information.
- (9) Commercial application for non-critical loads, ie. sprinklers controls and gates. PNM will allow socket without bypass handle.
- (10) Allowed on single manufactured and mobile homes ONLY. For mobile home parks see MS-5-4.0.
- (11) Ground wire connector and rod per NEC Article 250.
- (12) Equipped with lever arm bypass with jaw tension release.

**Residential Underground Service Entrance Conduit Size (Internal Diameter)**

Service Distance (ft)	*125A Class Meter Socket	200A Class Meter Socket	320A Class Meter Socket
100' or Less	3.0"	3.0"	3.0"
Greater than 100'	3.0"	3.0"	3.0"

- Contact your new service representative with the meter location and estimated load for more information.
- \*For manufactured and mobile homes ONLY
- Main breaker larger than 320 Amps See MS-3-7.0

**Approved Equipment**

Manufacturer	Item	Mfg Part #
Eaton	200A Ringless Pedestal	MHR200P
Milbank	200A Ringless Pedestal	U5136-O-200M-FMG
Milbank	200A Ringless Pedestal	U5136-O-200S-10GR

For ease of checking service without interruption, PNM will no longer allow ring meter sockets as of 12/01/2013.

**REFERENCES**

- (1) See DM-4-11.0 Maximum Available Fault Currents

120/240V 125 to 200A Rated Socket Pedestal Meter

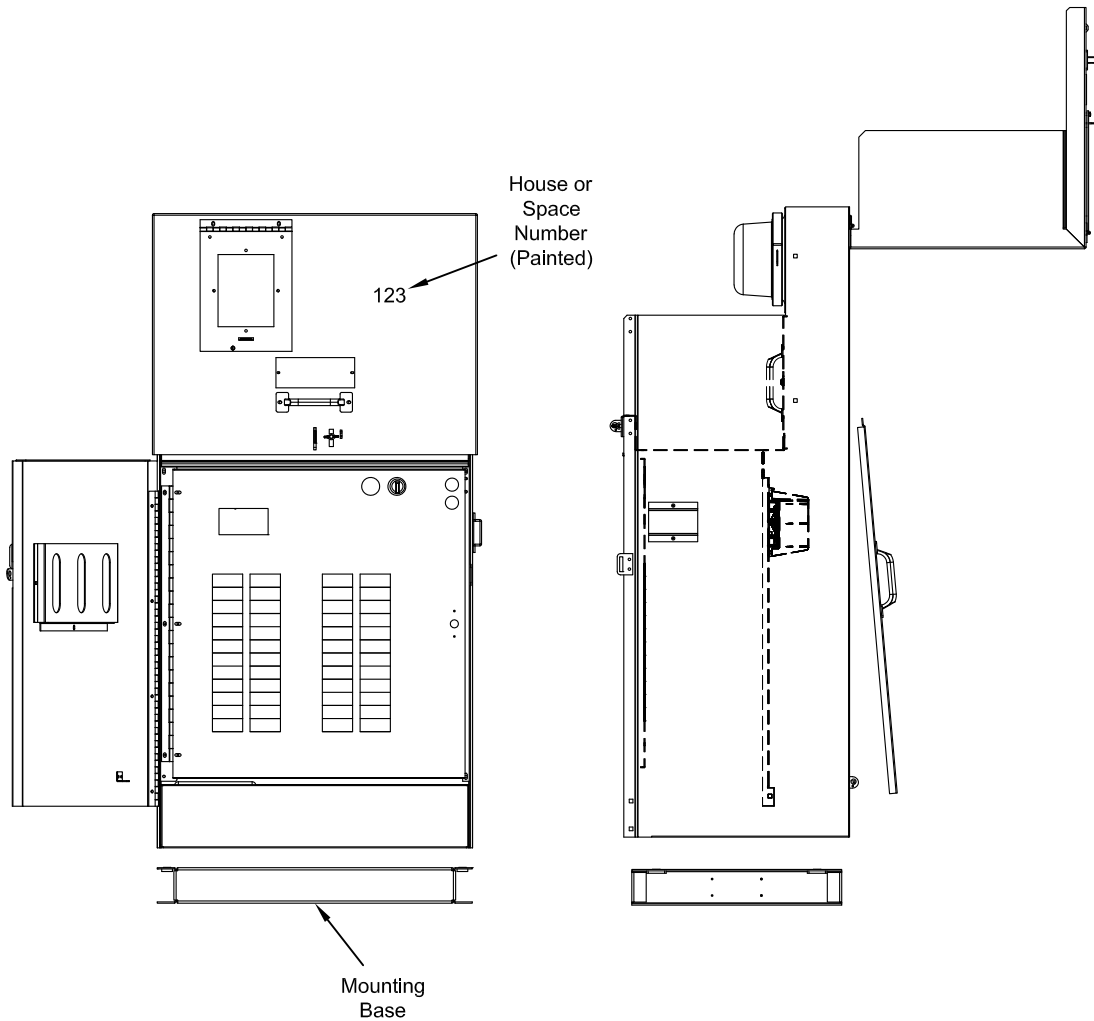

**NOTES**

- (1) Pedestal construction from 14 gauge steel with corrosion resistant finish.
- (2) Meter socket minimum rating 125A factory wired in separate wire way from terminal block to meter socket.
- (3) For services larger than 125A, a factory rated 200 or 320A pedestal must be used.
- (4) Insulated stud terminal block or bus pads to accommodate PNM connections.
- (5) Pedestal bonding lug grounding conductor must be continuous to breaker panel grounding terminal.
- (6) Termination section to have removable rain tight cover with provision for padlocking. All other removable portions of termination section must be sealable.
- (7) Rigid galvanized, schedule 80 PVC or IMC 90° elbow. If plastic conduit is used in place of rigid, it must be encased in 2" of concrete from where it enters metal enclosure, to 18" below ground level. End of elbow conduit run must extend beyond the edge of the concrete foundation.
- (8) Contact your new service representative with the meter location and estimated load for more information.
- (9) Commercial application for non-critical loads, ie. sprinklers controls and gates. PNM will allow socket without bypass handle.
- (10) Allowed on single manufactured and mobile homes ONLY. For mobile home parks see MS-5-4.0.
- (11) Ground wire connector and rod per NEC Article 250.
- (12) Equipped with lever arm bypass with jaw tension release.

**REFERENCES**

- (1) See DM-4-11.0 Maximum Available Fault Currents

Approved Equipment		
Manufacturer	Item	Mfg Part #
Milbank	320A Ringless Pedestal	CP3B5411GB22PBSP1

For ease of checking service without interruption, PNM will no longer allow ring meter sockets as of 12/01/2013.

Residential Underground Service Entrance Conduit Size (Internal Diameter)	
Service Distance (ft)	320A Class Meter Socket
100' or Less	3"
Greater than 100'	3"

- Contact your new service representative with the meter location and estimated load for more information.
- \*For manufactured and mobile homes ONLY
- Main breaker larger than 320 Amps See MS-3-7.0

**120/240V 320A Pedestal Meter**

**MS-5-2.0**

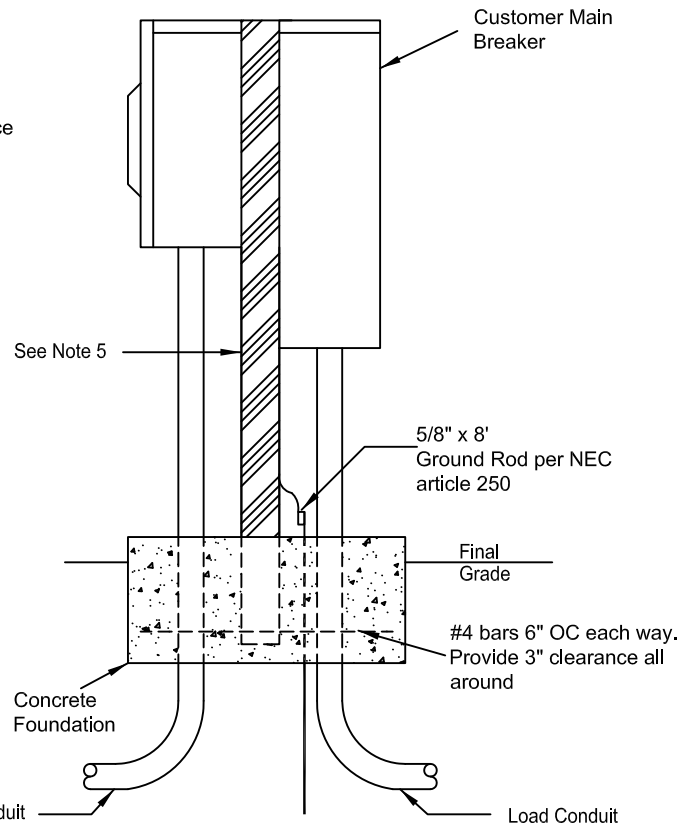
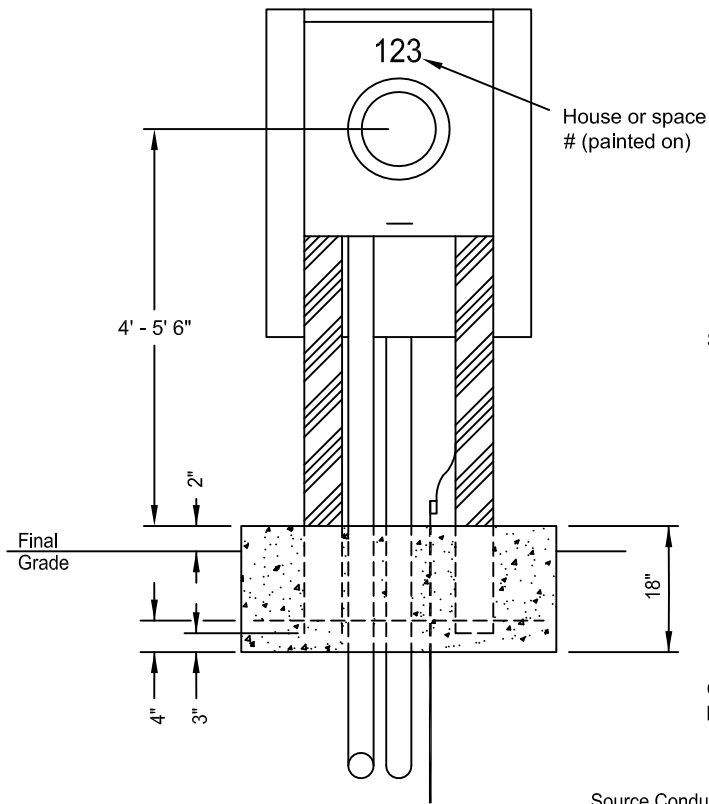
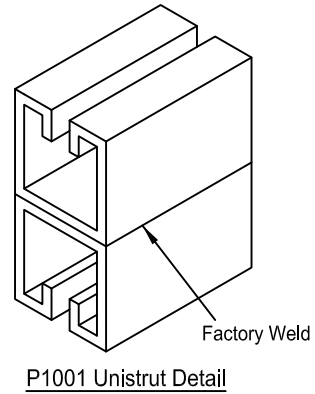
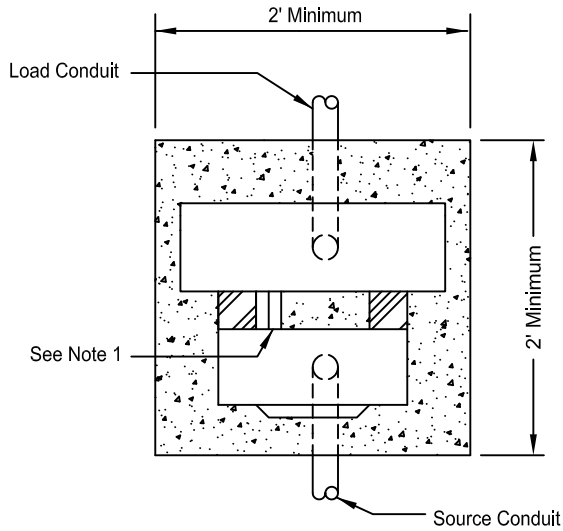

**NOTES**

- (1) Use rigid nipple between meter socket and main breaker.
- (2) Equipment shall be securely attached to support members either bolted directly or mounted to metal channel or unistrut cross members.
- (3) Rigid galvanized, Schedule 80 PVC or IMC conduit shall be used for source and load conduits. No junction box or cable trough is permitted ahead of the metering enclosure.
- (4) Guard posts will be required in traffic areas. As specified.
- (5) Acceptable support members are as follows:
  - 3" x 3" 1/2" Angle
  - 3" x 4.1 lbs/ft Channel
  - 2" x 2" 3/16" Box Steel
  - 2 1/2" Standard Pipe
  - P1001 Unistrut (See Steel Detail)

For ease of checking service without interruption, PNM will no longer allow ring meter sockets as of 12/01/2013.

**REFERENCES**

- (1) See DM-4-11.0 Maximum Available Fault Currents
- (2) See DS-7-16.10 Guard Post
- (3) See MS-2-2.0 120/240V 125/200A Permanent Overhead and Underground Single-Phase Meter Socket
- (4) See MS-2-5.0 120/240V 200A Single-Phase Meter Socket with Bypass
- (5) See MS-2-6.0 120/208 Wye or 120/240 Delta 200A Three-Phase Four-Wire Wye or Delta Meter Socket with Bypass

**Permanent Single-Phase or Three-Phase Pedestal Meter**

MS-5-3.0

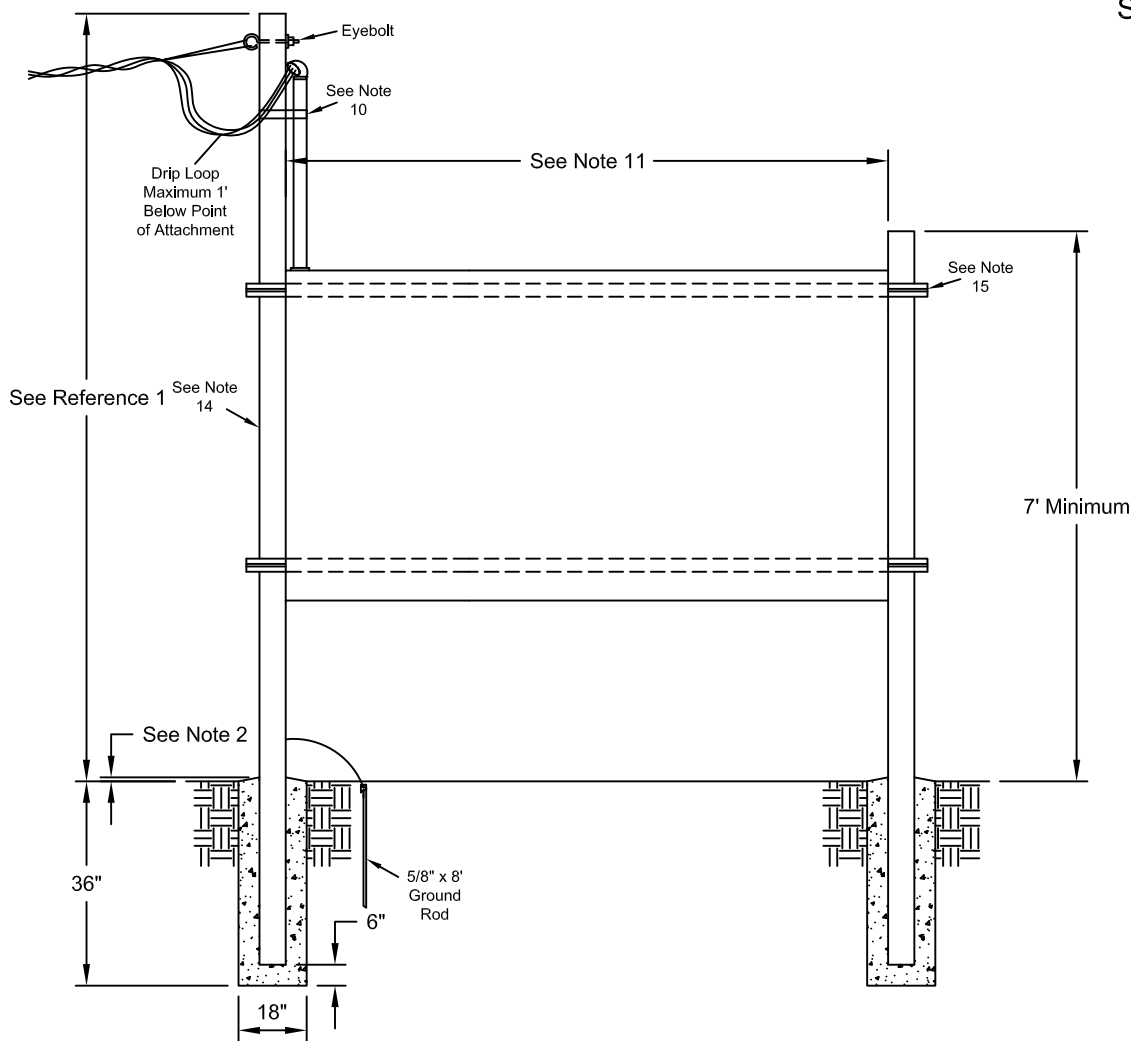

**NOTES**

- (1) Line duct must be rigid galvanized, IMC or EMT.
- (2) Concreted to be 1" above grade and tapered from post to ground.
- (3) Main disconnect may be required on the line side of any group of more than six meter sets to meet NEC, state, or local codes.
- (4) Top meter shall be a maximum of 4' - 5' 6" from finished grade bottom meter shall be minimum of 30" from finished grade.
- (5) PNM requires a minimum of 48" between front of above enclosures and any wall or obstruction.
- (6) All line feed sections shall be lockable and sealable by PNM.
- (7) All units shall be complete with sockets and breakers at the time of initial set of first meter.
- (8) Guard posts will be required in traffic areas.
- (9) Contact PNM customer service representative for height of service attachment point if service crosses driveways. Areas subject to vehicle traffic are specified herein for 12' attachment height. Higher attachment may require different supports.
- (10) Pipe strap shall be firmly attached to support member at intervals of 30" minimum.
- (11) If separation between support members is greater than 6' an additional center support of the same material will be required.
- (12) Metering installations shall be located along the front lot line. Contact PNM Electric Service delivery to coordinated a meter spot.
- (13) 480V can be used for Mobile Home Park and apartments.
- (14) Approved materials for support members:  
2 1/2" Pipe (min), 3" x 3" - 1/2" Angle Iron, 2" x 2" - 3/16" Box Steel. Capped or filled with concrete.
- (15) Approved material for backing:  
P1000 Unistrut Welded, 1/2" Plate Steel Welded and Painted.
- (16) PNM requires this gang metering Field Built Structure per MS-5-4.0 for new/upgrades to Mobile Home Parks. Please consult with you PNM representative before installing metering equipment in Mobile home Parks.

**REFERENCES**

- (1) See DS-4-4.5 Minimum Point of Attachment Height for Service Drop Cables
- (2) See DM-4-11.0 Maximum Available Fault Currents

Approved Equipment		
Manufacturer	Item	Mfg Part #
Eaton	200A OH/UG Ringless # Position	1MP****
Siemens	225A OH/UG Ringless # Position	WP4 *12RJ
Siemens	225A OH/UG Ringless # Position,	WP6 *12RJ
	600A Buss	
Siemens	225A OH/UG Ringless # Position,	WP8 *12RJ
	800A Buss	
Siemens	225A OH/UG Ringless # Position,	WP10 *12RJ
	1000A Buss	
Square D	200A OH/UG Ringless # Position	MPR4*200
Square D	225A OH/UG Ringless # Position	EZMR11*225
Square D	225A OH/UG Ringless # Position	EZMR31*225
Square D	200A OH/UG Ringless Bypass	MPH22125
Square D	200A OH/UG Ringless Bypass	MPH44125

\* There are various catalog #'s available for # of positions

For ease of checking service without interruption, PNM will no longer allow ring meter sockets as of 12/01/2013.

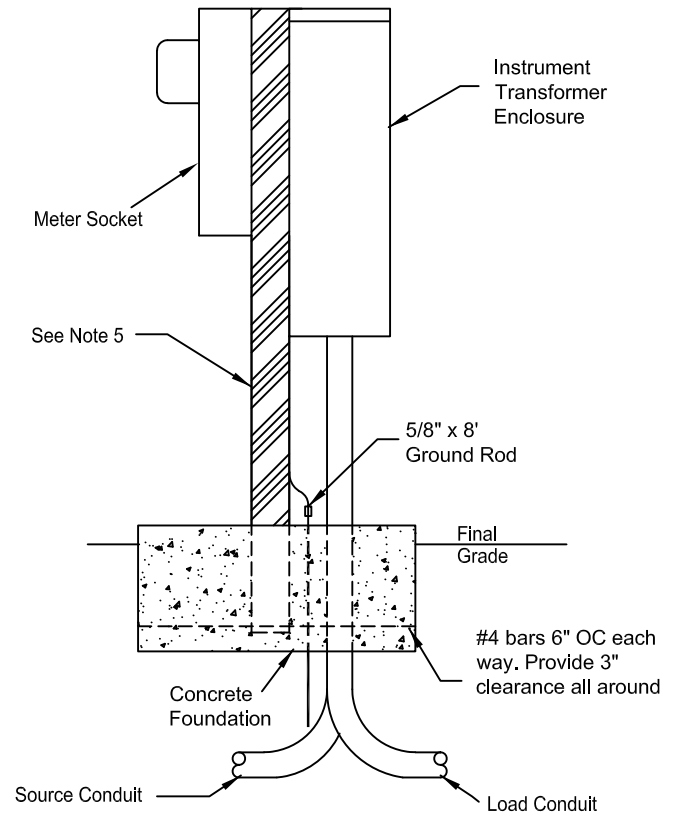
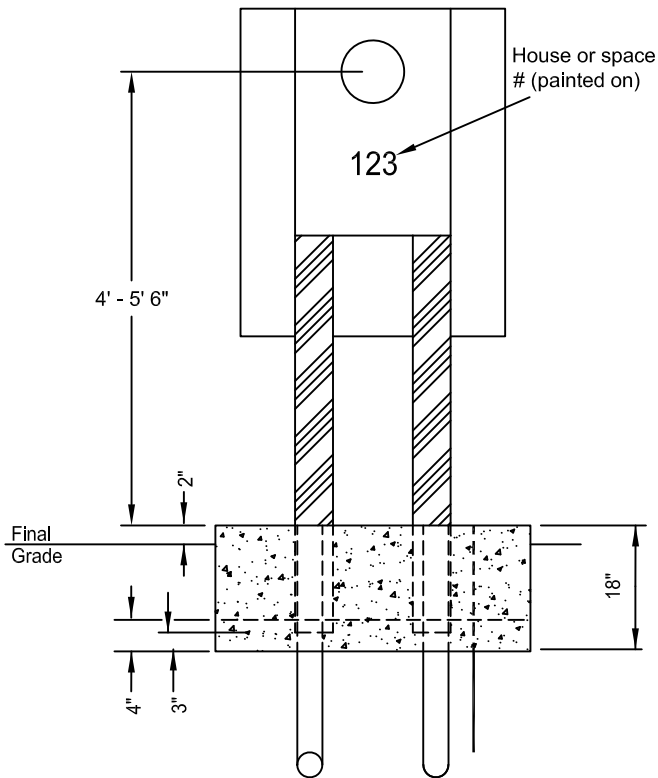
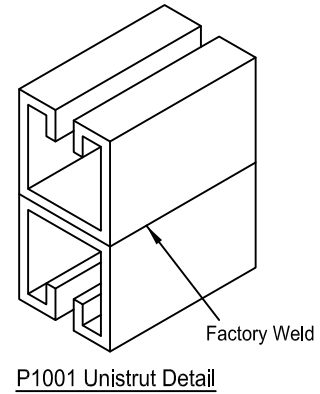
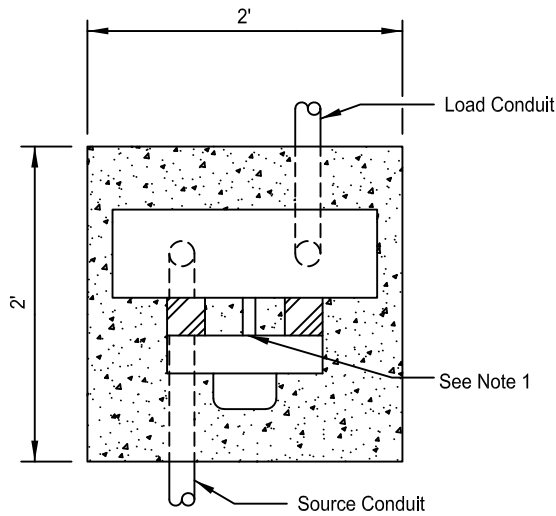

**NOTES**

- (1) Use 1" rigid nipple between instrument transformer enclosure and meter enclosure for secondary wiring.
- (2) Enclosures shall be securely attached to support members either bolted directly or mounted to metal channel or unistrut cross members.
- (3) Rigid galvanized, Schedule 80 PVC or IMC conduit shall be used for source and load conduits. No junction box or cable trough is permitted ahead of the metering enclosure.
- (4) Guard posts will be required in traffic areas as specified.
- (5) Acceptable support members are as follows:
  - 3" x 3"  $\frac{1}{2}$ " Angle
  - 3" x 4.1 lbs/ft Channel
  - 2" x 2"  $\frac{3}{16}$ " Box Steel
  - 2  $\frac{1}{2}$ " Standard Pipe
  - P1001 Unistrut (See Steel Detail)

**REFERENCES**

- (1) See DM-4-11.0 Maximum Available Fault Currents
- (2) See DS-7-16.10 Guard Post
- (3) See MS-2-7.0 Three-Phase Thirteen-Terminal CT Meter Socket
- (4) See MS-3-3.0 Recording Meter Instrument Transformer Enclosure

For ease of checking service without interruption, PNM will no longer allow ring meter sockets as of 12/01/2013.

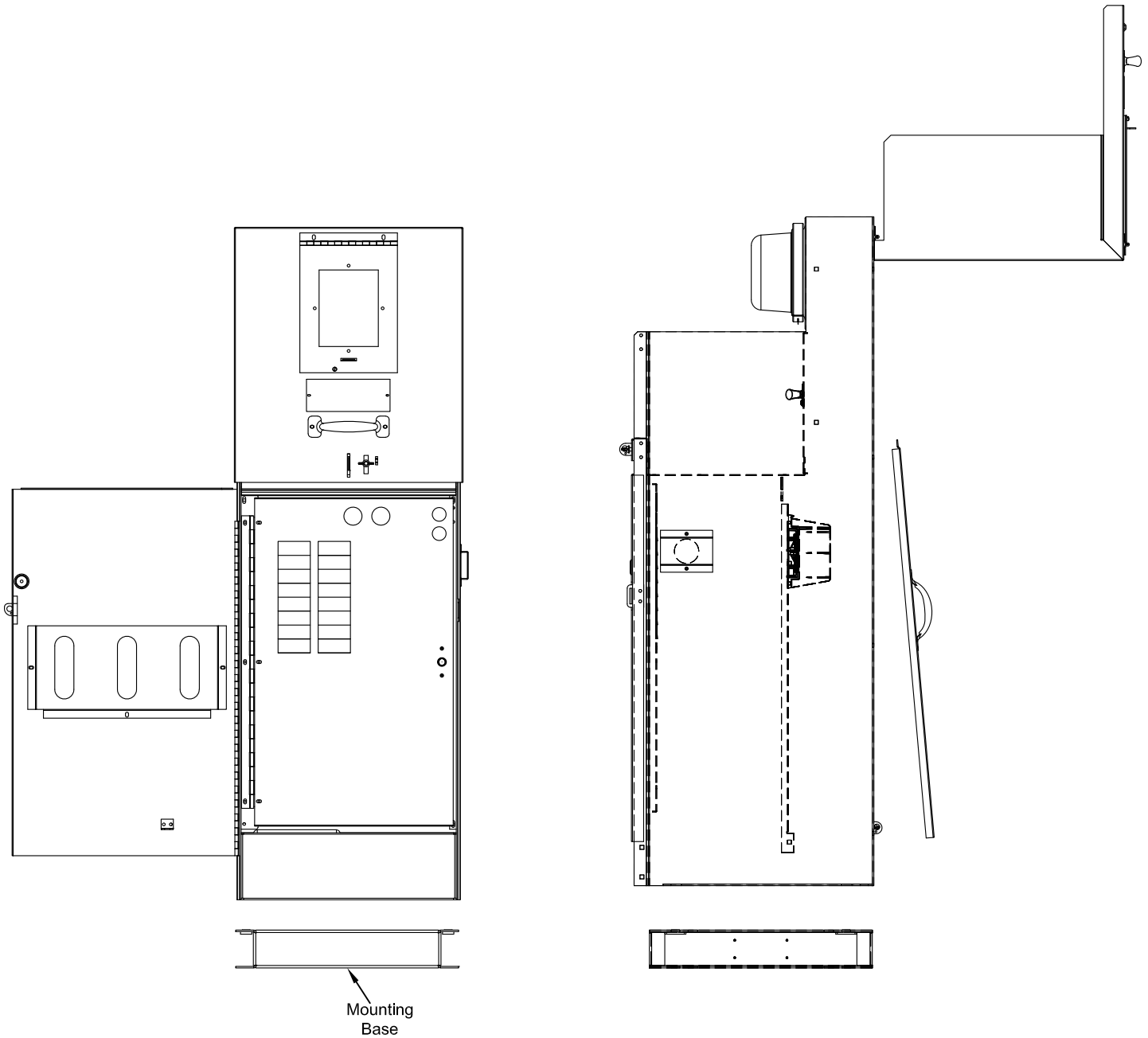

**NOTES**

- (1) Four 5/8 x 18" anchor bolts recommended.
- (2) Recommend 3" minimum foundation extension all sides.  
Recommend 6" minimum depth.
- (3) Minimum 36" clearance required per NEC 110-16 typical front/back.
- (4) Service ONLY Three-wire 240V

**REFERENCES**

- (1) See DM-4-11.0 Maximum Available Fault Currents

Approved Equipment		
Manufacturer	Item	Mfg Part #
Milbank	Ringless Pedestal with Bypass	CP3B51115A22
Milbank	Ringless Pedestal with Bypass	CP3B5111TA22
TESCO	Ringless Pedestal with Bypass	27000

For ease of checking service without interruption, PNM will no longer allow ring meter sockets as of 12/01/2013.

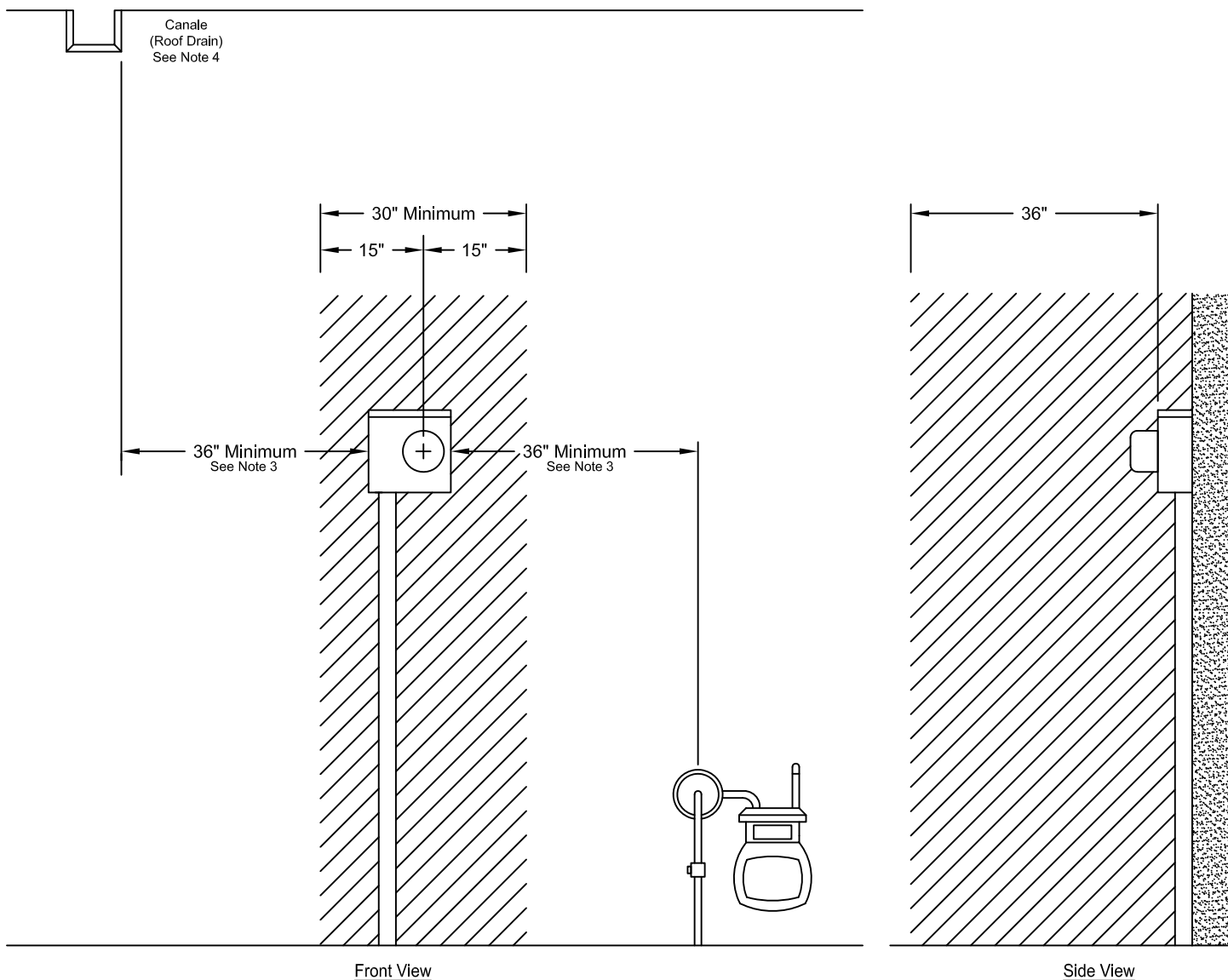

NOTES

- (1) Shaded area is considered working space and shall be kept clear of all obstacles (including landscaping) to permit ready and safe operation and maintenance of the service equipment.
- (2) Electric meter shall be protected with extended curbs or ballards (guard posts) in traffic areas to maintain working space.
- (3) Clearance from meter socket, gas regulator, canales (roof drains) is 36" minimum.
- (4) This drawing is to be used for dimensioning purposes only. Canales (roof drains) are NOT allowed to be installed over electric and gas meters.

REFERENCES

- (1) NEC 110-16 Working Space
- (2) See DS-7-16.10 Guard Post

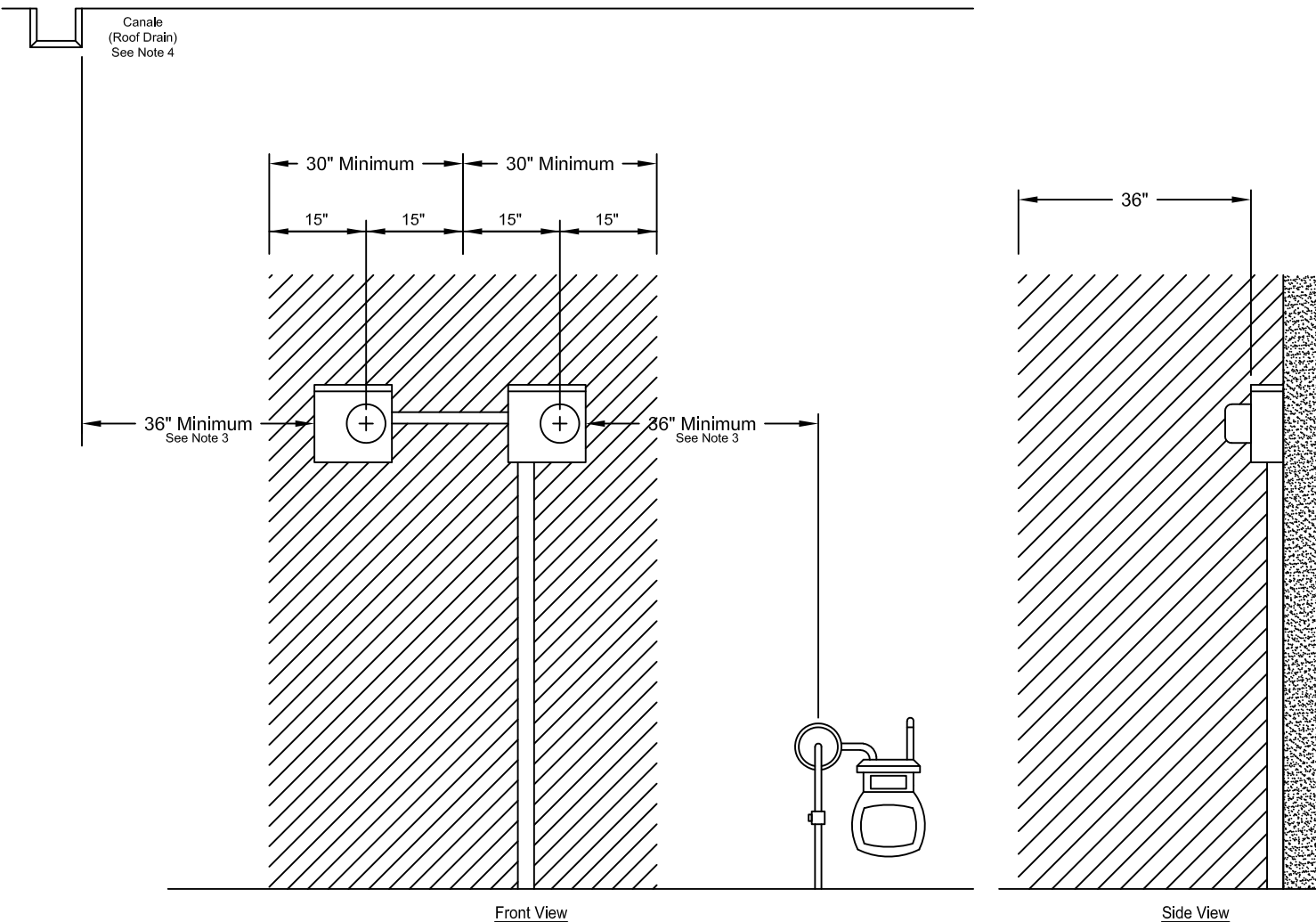

NOTES

- (1) Shaded area is considered working space and shall be kept clear of all obstacles (including landscaping) to permit ready and safe operation and maintenance of the service equipment.
- (2) Electric meter shall be protected with extended curbs or ballards (guard posts) in traffic areas to maintain working space.
- (3) Clearance from meter socket, gas regulator, canales (roof drains) is 36" minimum.
- (4) This drawing is to be used for dimensioning purposes only. Canales (roof drains) are NOT allowed to be installed over electric and gas meters.

REFERENCES

- (1) NEC 110-16 Working Space
- (2) See DS-7-16.10 Guard Post



COGEN  
with Mailbox

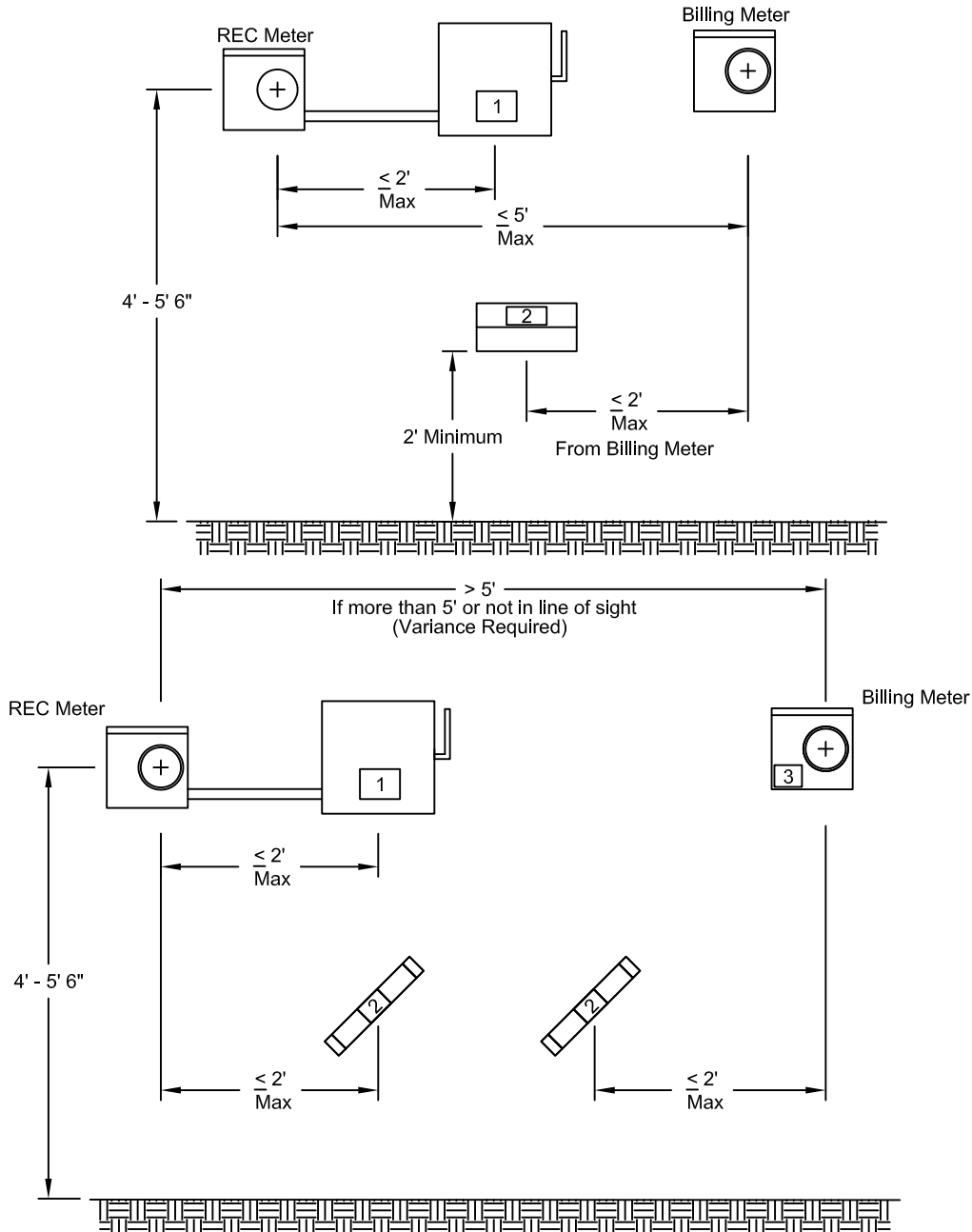

NOTES

- (1) Disconnect Label: Red etched placard on switch must identify type of COGEN and contain the language "Generation Disconnect", i. e. "PV Generation Disconnect" or "Energy Storage Disconnect" or "Wind generation Disconnect."
- (2) One-Line Electrical and Site Map: Weatherproof drawings located within 2' of billing meter. See table for approved methods.
- (3) If REC meter is greater than 5' from or not in line of site of the billing meter:
  - A red etched placard on the billing meter that reads "Warning Customer Owned Generation Connected. See drawing for disconnect location."
  - One-line and Site Map located within 2' if both REC and Billing meters.
- (4) To pass meter set inspection, all generator equipment and breakers must be ready in the ON position, and inverter is programmed and ready to operate. PNM cannot access or operated any customer owned equipment except for the utility meter and utility accessible Generation Disconnect.

APPROVED WEATHERPROOF METHODS FOR DRAWINGS:
Etched placard, legible and permanently fixed
Document canister by Agri Supply or equivalent
Mail box

ESS ONLY  
with Tube

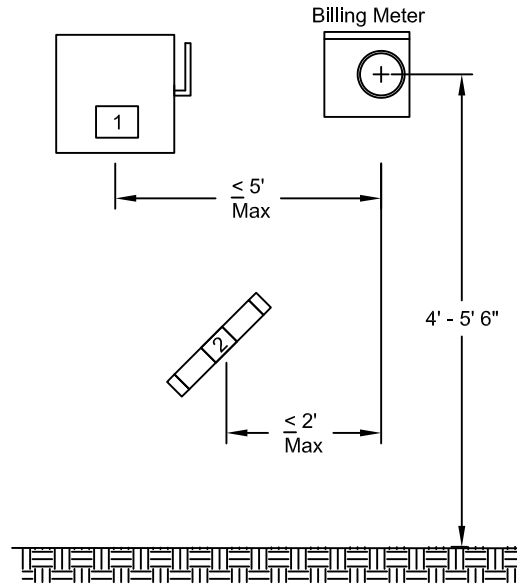

NOTES

- (1) Disconnect Label: Red etched placard on switch must identify type of COGEN and contain the language "Generation Disconnect", i. e. "PV Generation Disconnect" or "Energy Storage Disconnect" or "Wind generation Disconnect."
- (2) One-Line Electrical and Site Diagram: Weatherproof drawings located within 2' of billing meter. See table for approved methods.
- (3) If REC meter is greater than 5' from or not in line of site of the billing meter:
  - A red etched placard on the billing meter that reads "Warning Customer Owned Generation Connected. See drawing for disconnect location."
  - One-line and Site Map located within 2' if both and Billing meters.
- (4) To pass meter set inspection, all generator equipment and breakers must be ready in the ON position, and inverter programmed and ready to operate. PNM cannot access or operated any customer owned equipment except for the meter and utility accessible Generation Disconnect.

APPROVED WEATHERPROOF MEATHODS FOR DRAWINGS:

- (1) Etched placard, legible and permanently fixed.
- (2) Document canister by Agri Supply or equivalent
- (3) Mail box

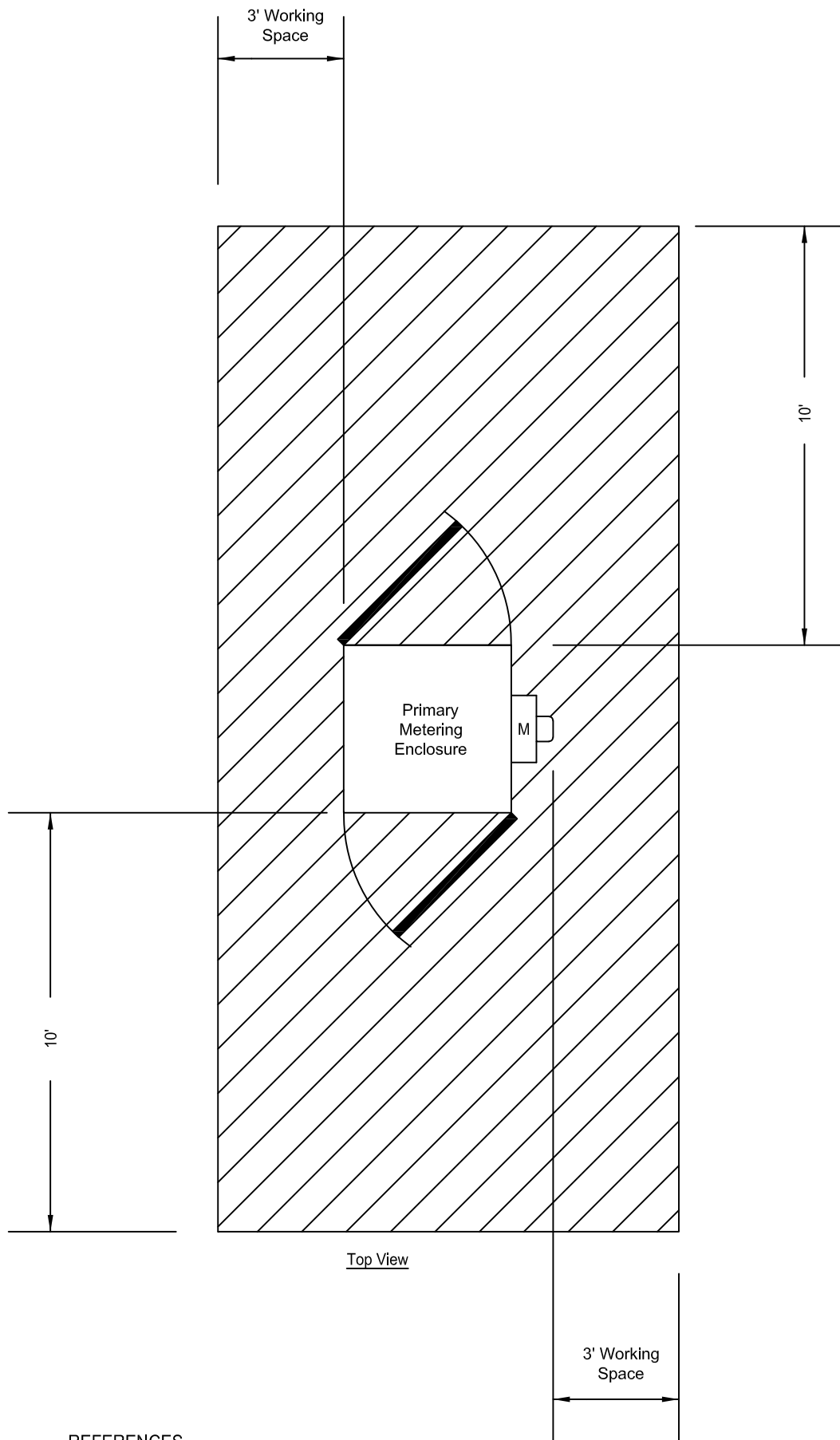

REFERENCES

- (1) See MS-3-16.0 120/208-277/480V Enclosure Pad
- (2) See MS-3-21.0 7900/12470V CT and PT Meter Enclosure Pad

Working Space Required for Primary Meter Enclosure

MS-7-2.0

**DIAGRAM DISCLAIMER**

Connections Shown are for Illustrative Purposes Only  
 This sketch is intended to be used for illustrative purpose only.  
 This sketch is not intended to provide an NEC compliant  
 electrical design or directives for full NEC compliance.

PNM  
 METER  
 STANDARD

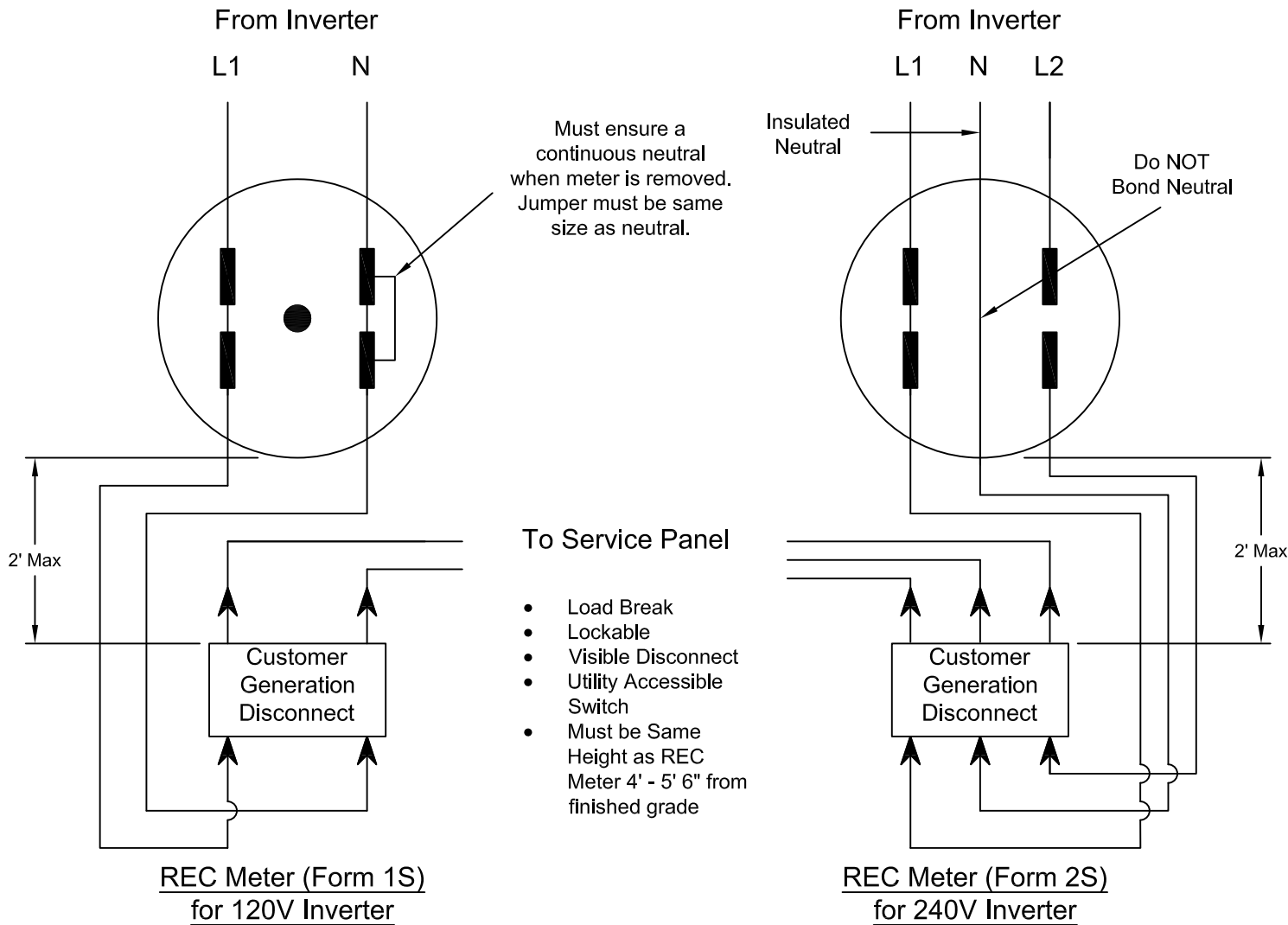

**NOTES**

- (1) Check with your new service representative if you have a special voltage requirements.
- (2) Do not bond the neutral to the meter case. Ground the meter case with an equipment grounding conductor or by metallic conduit.
- (3) A REC meter cannot be installed in a Multiple Meter Center.
- (4) If supply side connection, Customer Generation Disconnect must be service entrance rated.
- (5) Metering and instrument cabinets shall not be used to house Customer-owned equipment, such as distribution panels or other equipment, nor used as a junction box/trough for the distribution of circuits.
- (6) Fused disconnect must be used for systems 50kW and larger.
- (7) Meter shall be 4' - 5' 6" from finished grade.

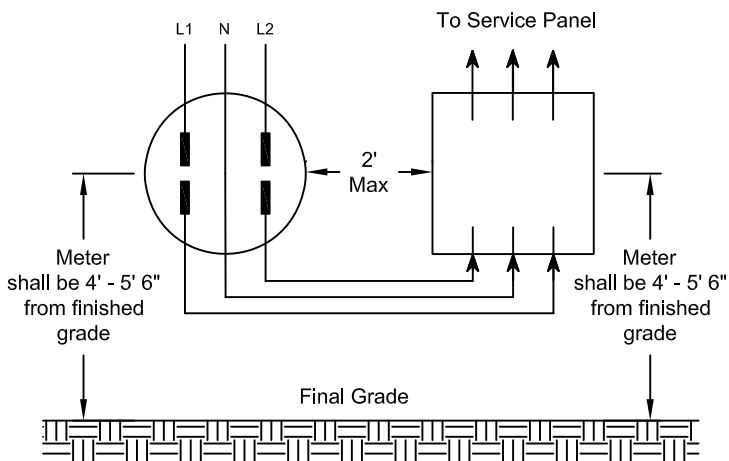
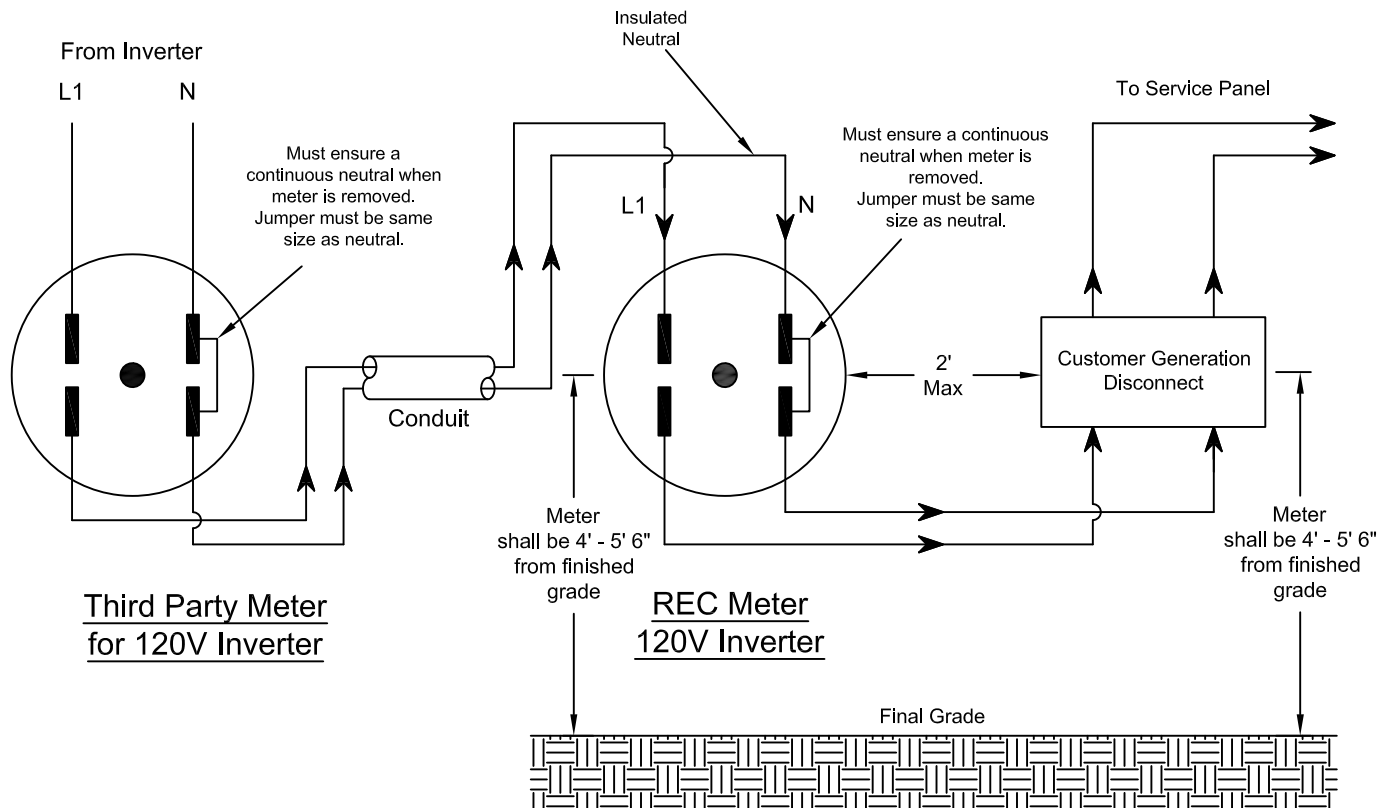

**DIAGRAM DISCLAIMER**

Connections Shown are for Illustrative Purposes Only  
 This sketch is intended to be used for illustrative purpose only.  
 This sketch is not intended to provide an NEC compliant  
 electrical design or directives for full NEC compliance.

**PNM  
 METER  
 STANDARD**

- Load Break
- Lockable
- Visible Disconnect
- Utility Accessible Switch
- Must be Same Height as REC Meter 4' - 5' 6" from finished grade



**NOTES**

- (1) Check with your new service representative if you have a special voltage requirements.
- (2) Do not bond the neutral to the meter case. Ground the meter case with an equipment grounding conductor or by metallic conduit.
- (3) A REC meter cannot be installed in a Multiple Meter Center.
- (4) If supply side connection, Customer Generation Disconnect must be service entrance rated.
- (5) Metering and instrument cabinets shall not be used to house Customer-owned equipment, such as distribution panels or other equipment, nor used as a junction box/trough for the distribution of circuits.
- (6) Meter shall be 4' - 5' 6" from finished grade.

**DIAGRAM DISCLAIMER**

Connections Shown are for Illustrative Purposes Only  
 This sketch is intended to be used for illustrative purpose only.  
 This sketch is not intended to provide an NEC compliant  
 electrical design or directives for full NEC compliance.

PNM  
 METER  
 STANDARD

- Load Break
- Lockable
- Visible Disconnect
- Utility Accessible Switch
- Must be Same Height as REC Meter 4' - 5' 6" from finished grade

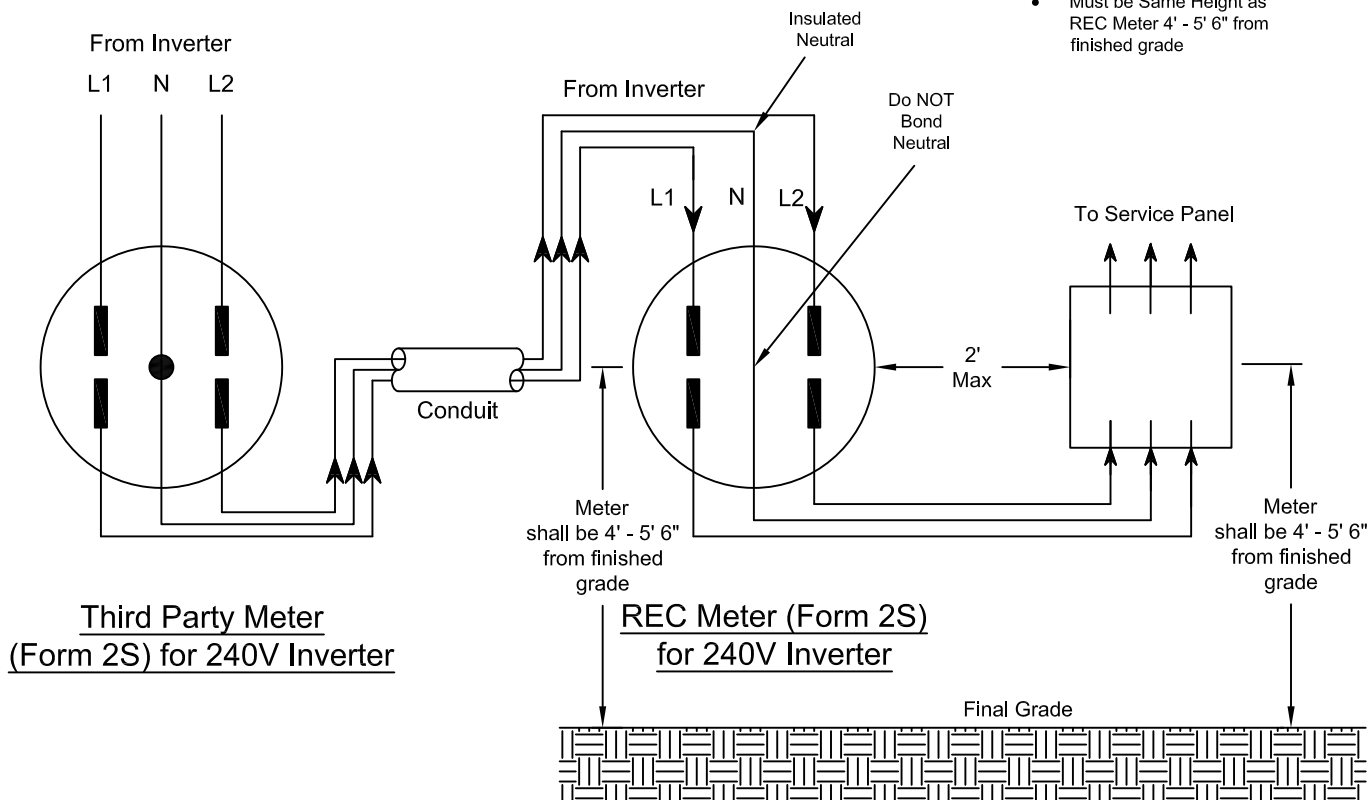

NOTES

- (1) Check with your new service representative if you have a special voltage requirements.
- (2) Do not bond the neutral to the meter case. Ground the meter case with an equipment grounding conductor or by metallic conduit.
- (3) A REC meter cannot be installed in a Multiple Meter Center.
- (4) If supply side connection, Customer Generation Disconnect must be service entrance rated.
- (5) Metering and instrument cabinets shall not be used to house Customer-owned equipment, such as distribution panels or other equipment, nor used as a junction box/trough for the distribution of circuits.
- (6) Fused disconnect must be used for systems 50kW and larger.
- (7) Meter shall be 4' - 5' 6" from finished grade.

Third Party Meter with REC Meter Base

Standard 240V Meter Base - Neutral NOT Bonded

MS-8-1.2

**DIAGRAM DISCLAIMER**

Connections Shown are for Illustrative Purposes Only  
 This sketch is intended to be used for illustrative purpose only.  
 This sketch is not intended to provide an NEC compliant  
 electrical design or directives for full NEC compliance.

PNM  
 METER  
 STANDARD

- Load Break
- Lockable
- Visible Disconnect
- Utility Accessible Switch
- Must be Same Height as REC Meter 4' - 5' 6" from finished grade

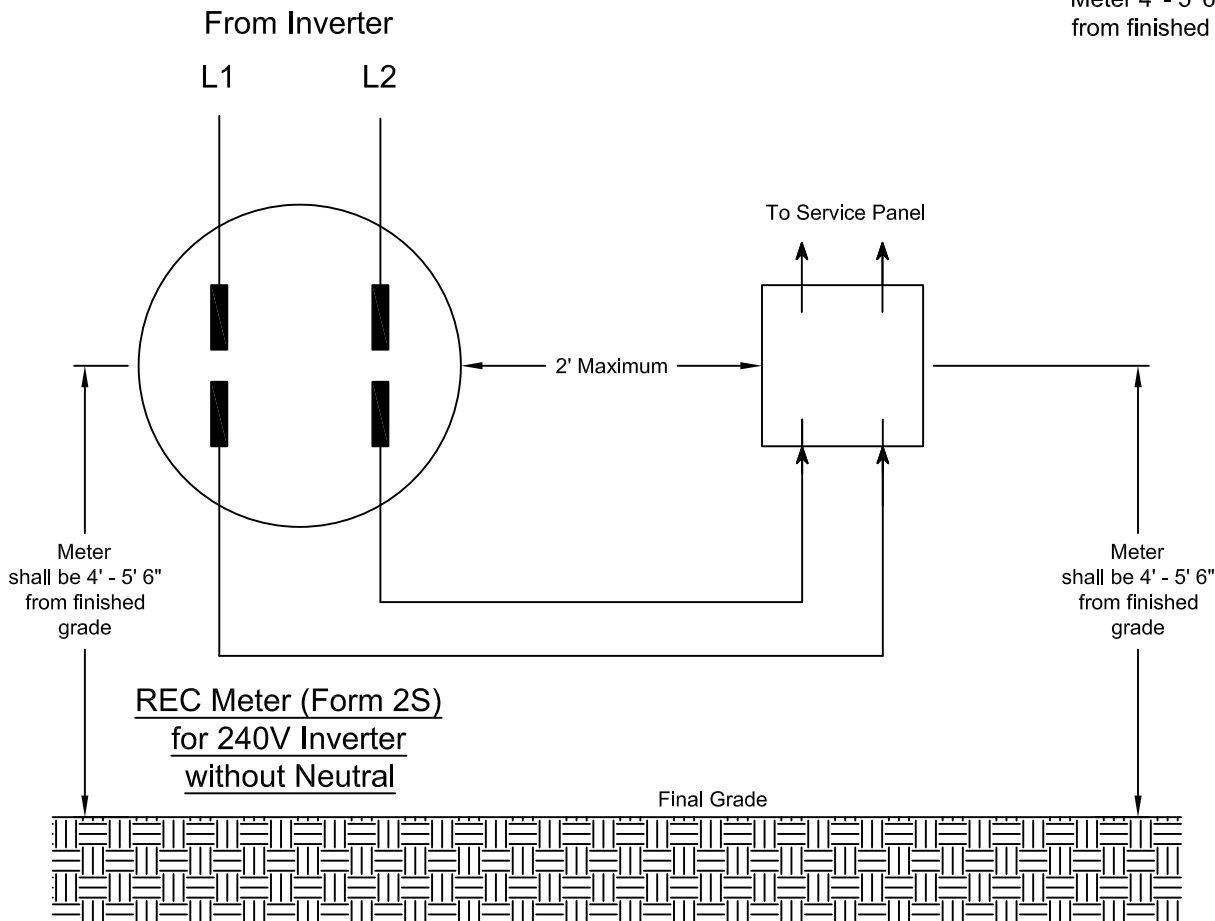

**NOTES**

- (1) Check with your new service representative if you have special voltage requirements.
- (2) A REC meter cannot be installed in a Multiple Meter Center.
- (3) If supply side connection, Customer Generation Disconnect must be service entrance rated.
- (4) Metering and instrument cabinets shall not be used to house Customer-owned equipment, such as distribution panels or other equipment, nor used as a junction box/trough for the distribution of circuits.
- (5) Fused disconnect must be used for systems 50kW and larger.
- (6) Meter shall be 4' - 5' 6" from finished grade.

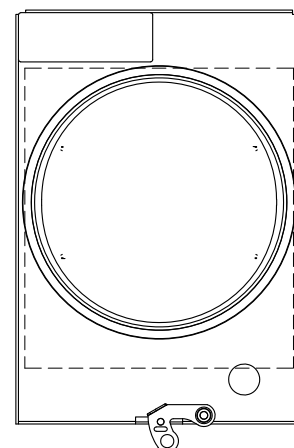
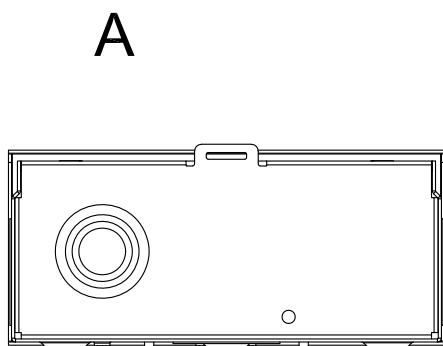
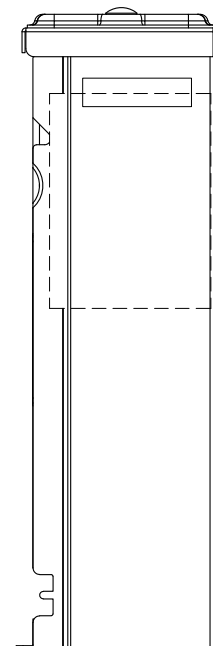
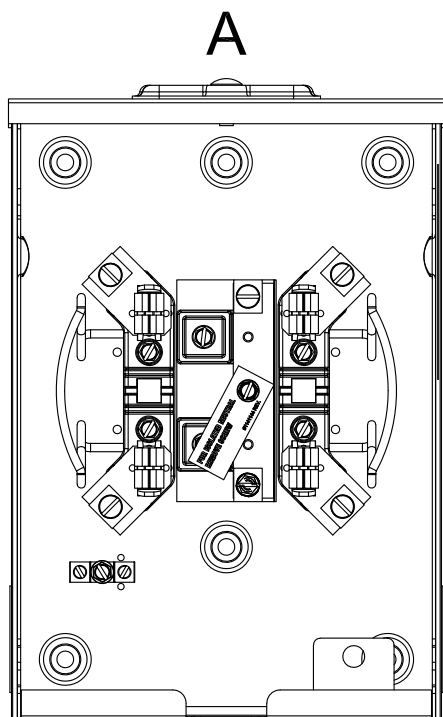

**NOTES**

- (1) Socket to be Underwriters Laboratory (UL) listed and same as, or similar to the above drawings.
- (2) Connections for terminating service conductors are the lay-in type.
- (3) Service duct to enter at point "A"
- (4) 120/240V Overhead and customer owned underground or overhead and underground temporary service only.
- (5) Meter shall be 4' - 5' 6" from finished grade.
- (6) Prior approval is required by Meter Department for all non-standard meter sockets.
- (7) Commercial application for non-critical loads, i.e. sprinkler control and gates. PNM will allow socket without bypass handle.
- (8) PNM does not permit a trough ahead of meter socket.
- (9) Metering and instrument cabinets shall not be used to house Customer-owned equipment, such as distribution panels or other equipment, nor used as a junction box/trough for the distribution of circuits.

**REFERENCES**

- (1) See DS-4-6.0 120/240V Underground Service Pole
- (2) See DS-4-8.0 Overhead Permanent/Temporary Single-Phase or Temporary Three-Phase Service Pole
- (3) See DS-4-9.0 Underground Residential Customer-Owned Service
- (4) See DM-4-11.0 Maximum Available Fault Current
- (5) See MS-8-1.0 REC Meter Base Standard 120/240V Meter Base-Neutral NOT Bonded
- (6) See MS-8-1.5 REC Meter Base Standard 240V Meter Base without Neutral

Approved Equipment		
Manufacturer	Item	Mfg Part #
Durham	100A OH/UG Ringless Socket	UTRS101B
Eaton	125A OH Ringless Socket	MBT48B125BTS
Eaton	125A OH/UG Ringless Socket	UTRS101BE
Eaton	125A OH Ringless Socket	1MP***
GE	125A OH/UG Ringless Socket	UHTRS101BGE
Milbank	125A OH/UG Ringless Socket	U7487-RL-TG
Milbank	125A OH/UG Ringless Socket	U5934-XL-BLG
Square D	125A OH Ringless Socket	RC8165100CH
Square D	125A OH/UG Ringless Socket	UTRS101B
Square D	100A OH/UG Ringless Socket	UGHTRS101B

\* Varies depending on hub size.

For ease of checking service without interruption, PNM will no longer allow ring meter sockets as of 12/01/2013.

120/240V 100-150A Single-Phase REC Meter Socket  
for Renewable Systems 10 kW or Less

MS-8-2.0



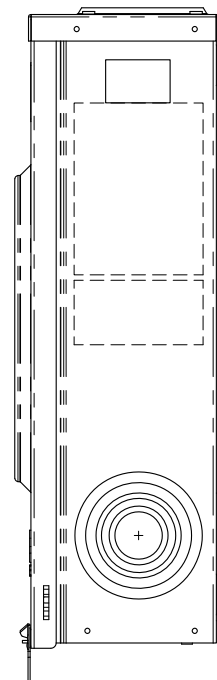
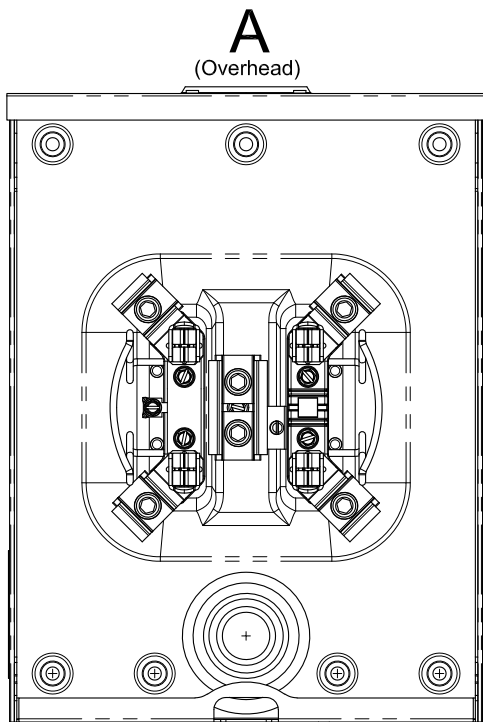

**Allowable Uses**

- 120/240 V  
Permanent/Temporary  
Services ONLY

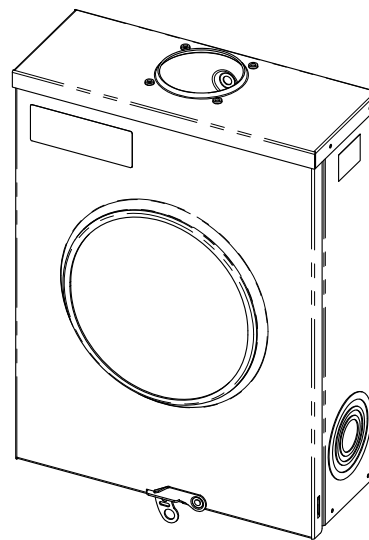
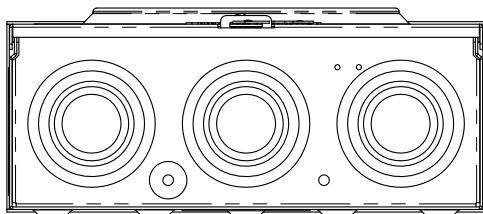

**NOTES**

- (1) Socket to be Underwriters Laboratory (UL) listed.
- (2) Connections for terminating service conductors shall be the lay-in type lug.
- (3) Service conduit to enter at point "A"
- (4) Meter shall be 4' - 5' 6" from finished grade.
- (5) Commercial application for non-critical loads i.e. sprinkler control and gates. PNM will allow socket without bypass handle.
- (6) PNM does not permit a trough ahead of meter socket.
- (7) Metering and instrument cabinets shall not be used to house Customer-owned equipment, such as distribution panels or other equipment, nor used as a junction box/trough for the distribution of circuits.
- (8) Customer building numbers must be permanently painted on proper meter panels.

**REFERENCES**

- (1) See DS-4-6.0 120/240V Underground Service Pole
- (2) See DS-4-8.0 Overhead Permanent/Temporary Single-Phase or Temporary Three-Phase Service Pole
- (3) See DS-4-9.0 Underground Residential Customer-Owned Service
- (4) See DM-4-11.0 Maximum Available Fault Current
- (5) See MS-3-7.0 Over 320A 240V Single-Phase Meter

Approved Equipment		
Manufacturer	Item	Mfg Part #
Eaton	200A OH Ringless Socket	UTRS202BCH
Eaton	200A OH/UG Ringless Socket	UTRS212BCH
Eaton	200A OH/UG Ringless Socket	UTRS213BE
Milbank	200A OH Ringless Socket	U7021-RL-TG
Milbank	200A OH Ringless Socket	U7040-RL-TG
Milbank	200A OH/UG Ringless Socket	U7040-XL-TG
Milbank	200A OH/UG Ringless Socket	U4801-XL-5T9
Siemens	200A OH Ringless Socket	SUAT317-0G
Siemens	200A OH Ringless Socket	UAT317-0G
Square D	200A OH Ringless Socket	UTRS202B
Square D	200A OH/UG Ringless Socket (5th Jaw to be removed)	UTH5213T
Square D	200A OH/UG Ringless Socket	UTH7213T
Talon	200A OH Ringless Socket	UAT417-XGF

For ease of checking service without interruption, PNM will no longer allow ring meter sockets as of 12/01/2013.

240V 200A Customer Overhead or Underground  
Single-Phase Meter Socket 10.1 kW or Greater

MS-8-2.5

In the socket and at the weatherhead the colors green or white are not permitted to mark permanently phases one, two and three.

- Load Break
- Lockable
- Visible Disconnect
- Utility Accessible Switch
- Must be Same Height as REC Meter 4' - 5' 6" from finished grade

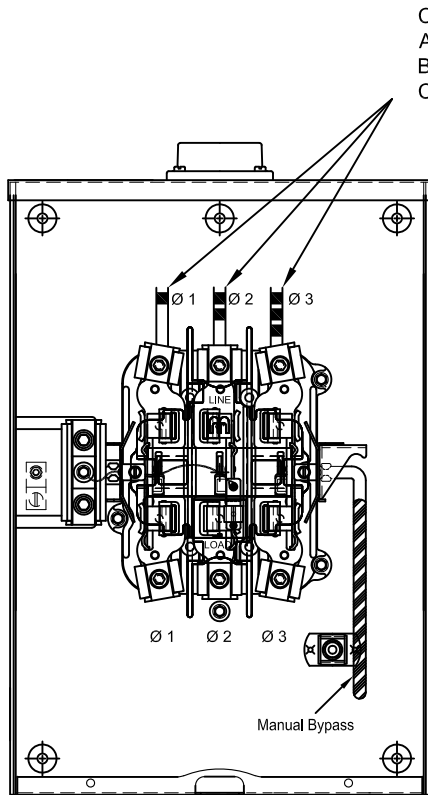

Conductor Wrap  
A - 1 Wrap  
B - 2 Wrap  
C - 3 Wrap

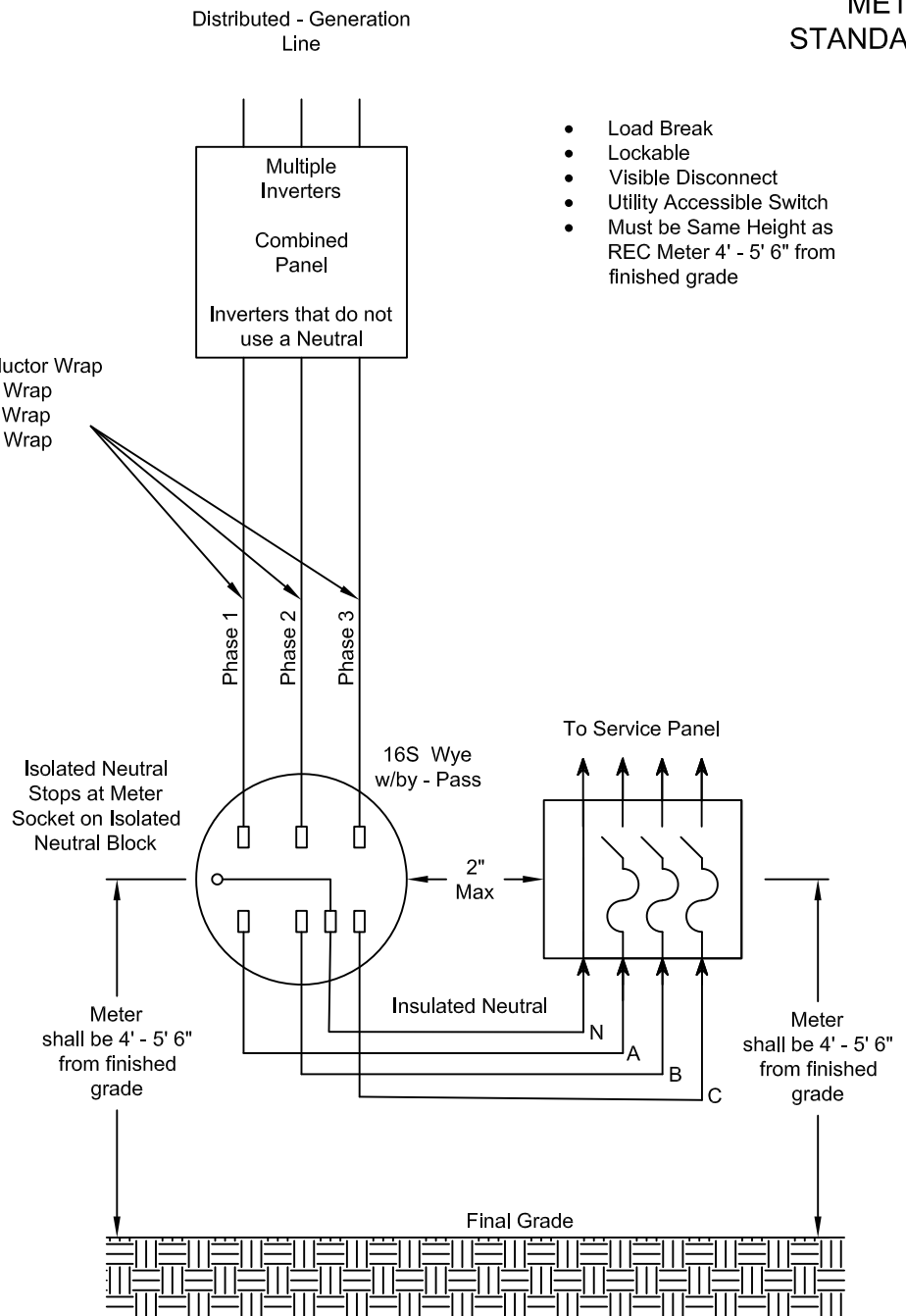

**NOTES**

- (1) Check with your new service representative if you have special voltage requirements.
- (2) To remove the meter first open Customer-Generation Disconnect and then remove the meter.
- (3) If supply side connection, Customer Generation Disconnect must be service entrance rated.
- (4) Must have three phase outputs.
- (5) Metering and instrument cabinets shall not be used to house Customer-owned equipment, such as distribution panels or other equipment, nor used as a junction box/trough for the distribution of circuits.
- (6) Fused disconnect must be used for systems 50kW and larger.
- (7) Meter shall be 4' - 5' 6" from finished grade.

Approved Equipment		
Manufacturer	Item	Mfg Part #
Durham	200A OH Socket	UT-H7203B
Durham	200A OH/UG Socket	UT-H7213
Landis & Gyr	200A OH Socket	HQ7-400701F
Landis & Gyr	200A UG Socket	HQ7U-400701F
Milbank	200A OH/UG Socket	NU9701-RXL

For ease of checking service without interruption, PNM will no longer allow ring meter sockets as of 12/01/2013.

277/480V, 120/208V Four-Wire Ground Wye  
1 Inverter, 3 Outputs without Neutral

MS-8-3.0

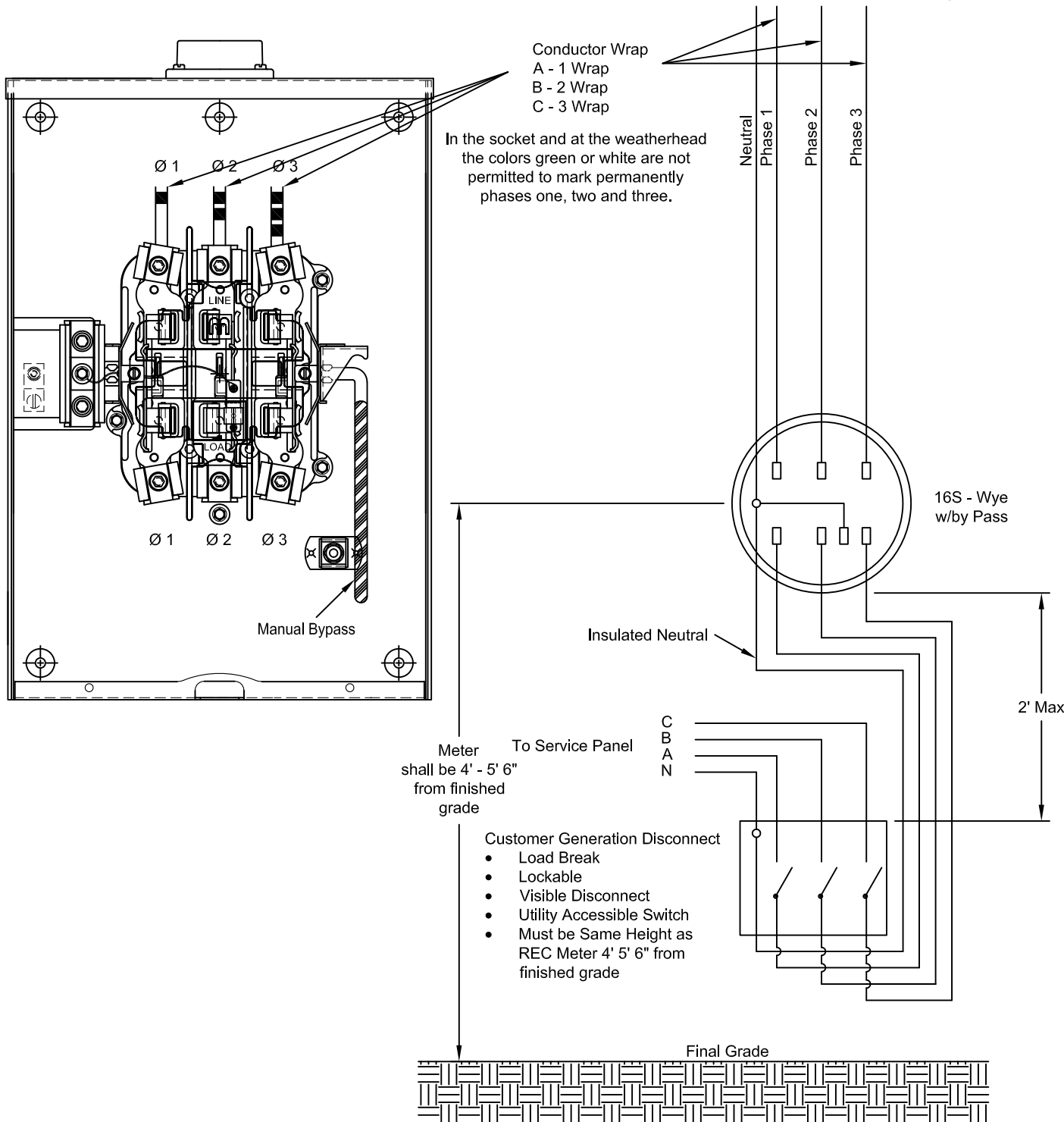

**NOTES**

- (1) Check with your new service representative if you have special voltage requirements.
- (2) To remove the meter first open Customer-Generation Disconnect and then remove the meter.
- (3) If supply side connection, Customer Generation Disconnect must be service entrance rated.
- (4) Must have three phase outputs.
- (5) Metering and instrument cabinets shall not be used to house Customer-owned equipment, such as distribution panels or other equipment, nor used as a junction box/trough for the distribution of circuits.
- (6) Meter shall be 4' - 5' 6" from finished grade.

Approved Equipment		
Manufacturer	Item	Mfg Part #
Durham	200A OH Socket	UT-H7203B
Durham	200A OH/UG Socket	UT-H7213
Landis & Gyr	200A OH Socket	HQ7-400701F
Landis & Gyr	200A UG Socket	HQ7U-400701F
Milbank	200A OH/UG Socket	NU9701-RXL

For ease of checking service without interruption, PNM will no longer allow ring meter sockets as of 12/01/2013.

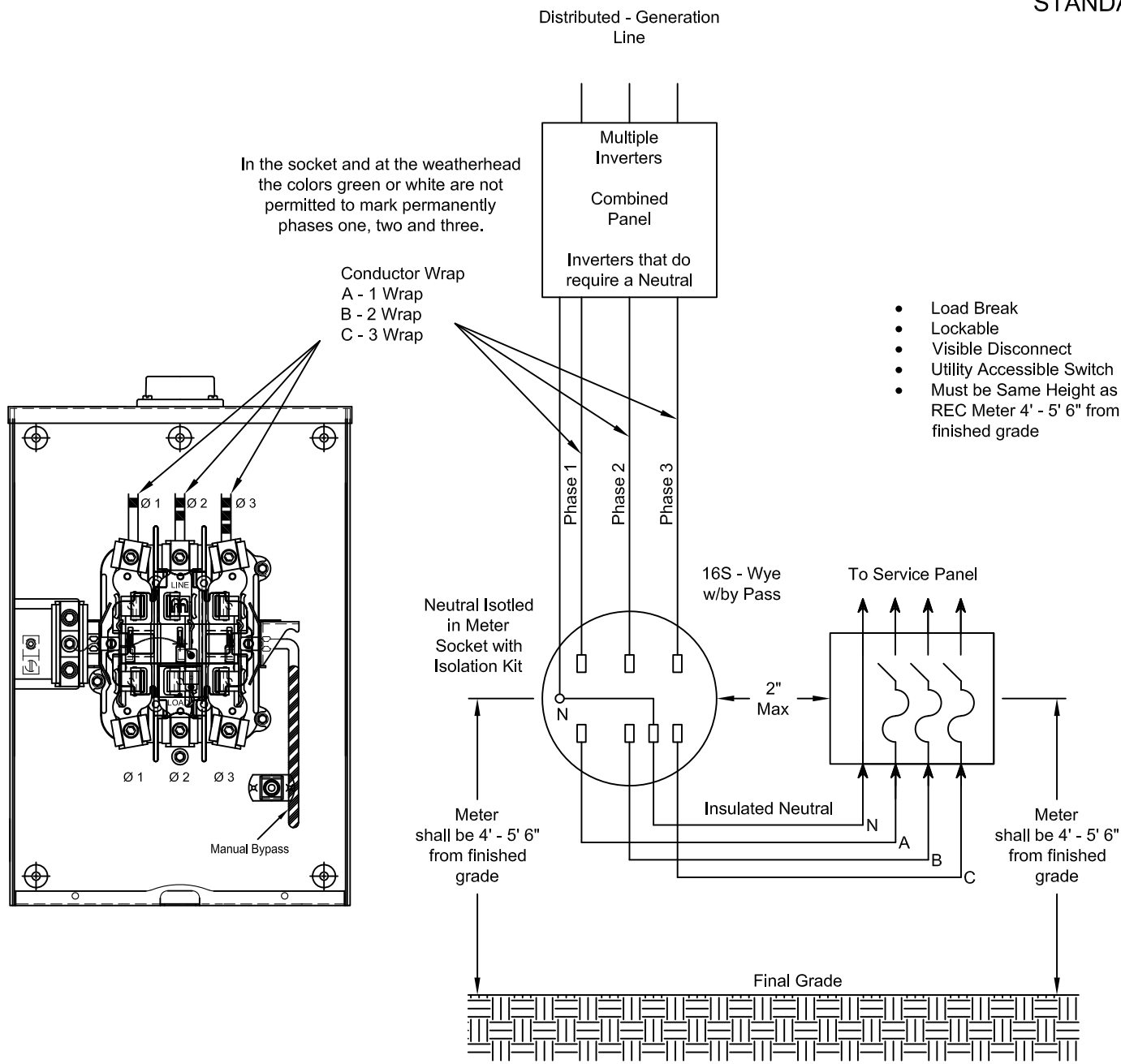

**NOTES**

- (1) Check with your new service representative if you have special voltage requirements.
- (2) To remove the meter first open Customer-Generation Disconnect and then remove the meter.
- (3) If supply side connection, Customer Generation Disconnect must be service entrance rated.
- (4) Must have three phase outputs.
- (5) Metering and instrument cabinets shall not be used to house Customer-owned equipment, such as distribution panels or other equipment, nor used as a junction box/trough for the distribution of circuits.
- (6) Fused disconnect must be used for systems 50kW and larger.
- (7) Meter shall be 4' - 5' 6" from finished grade.

Approved Equipment		
Manufacturer	Item	Mfg Part #
Durham	200A OH Socket	UT-H7203B
Durham	200A OH/UG Socket	UT-H7213
Landis & Gyr	200A OH Socket	HQ7-400701F
Landis & Gyr	200A UG Socket	HQ7U-400701F
Milbank	200A OH/UG Socket	NU9701-RXL

For ease of checking service without interruption, PNM will no longer allow ring meter sockets as of 12/01/2013.

277/480V, 120/208V Four-Wire Ground Wye  
3 Inverters, 3 Outputs with Neutral

MS-8-3.7

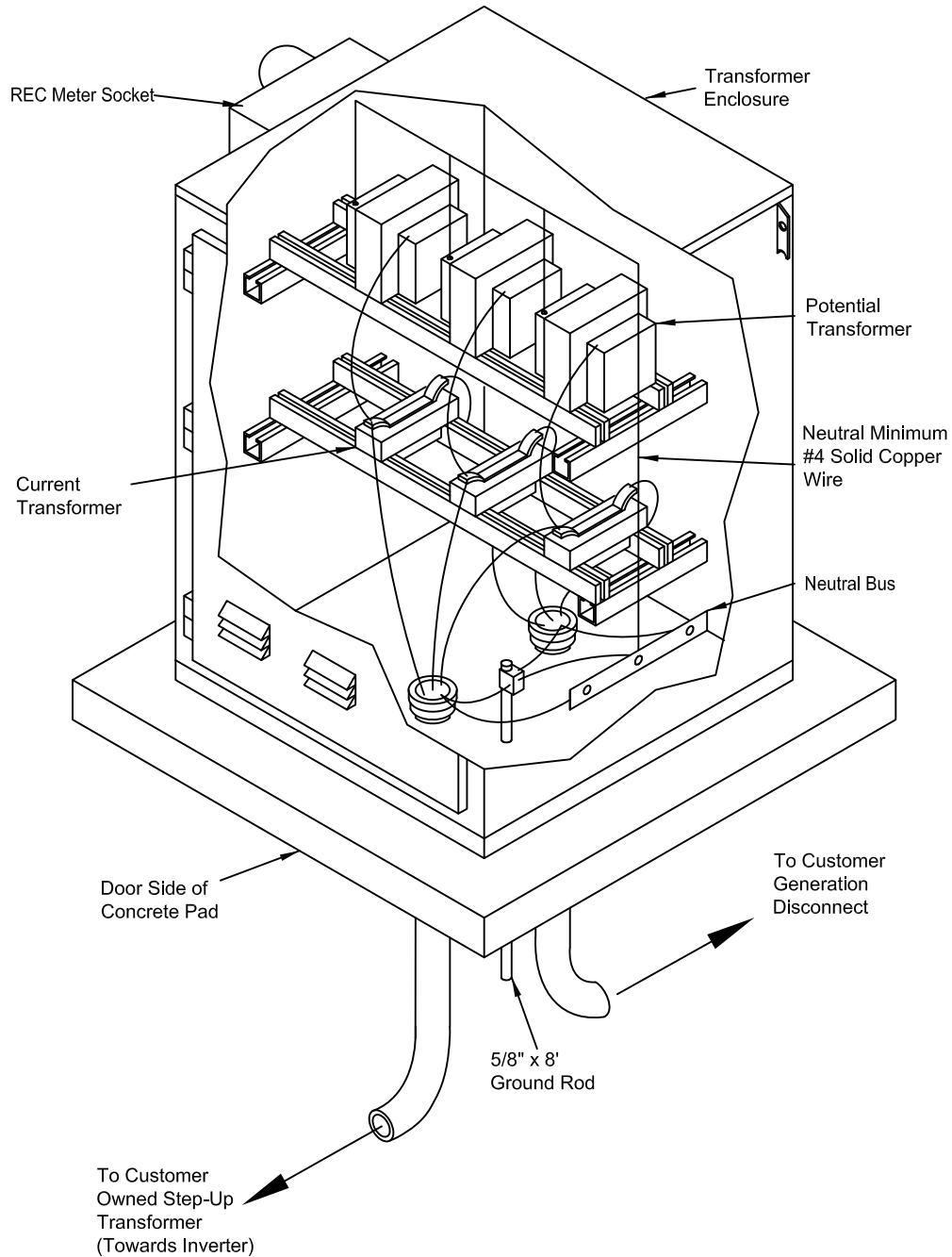

**NOTES**

- (1) Customer will furnish both meter socket and CT enclosure and deliver to PNM.
- (2) 15 kV cable shown as heavy lines.
- (3) Minimum clearance between 15 kV non-shielded cable and ground is 7 1/2".
- (4) Customer will furnish and install 4" rigid galvanized or IMC duct and concrete pad.
- (5) Metering and instrument cabinets shall not be used to house Customer-owned equipment, such as distribution panels or other equipment, nor used as a junction box/trough for the distribution of circuits.

**REFERENCES**

- (1) See MS-1-22.0 2400/4160-7200/12470V Wye Primary Meter
- (2) See MS-2-7.0 Three-Phase Thirteen-Terminal Socket for CT Meter
- (3) See MS-3-17.0 7200/12470V CT and PT Meter Enclosure
- (4) See MS-3-20.0 7200/12470V CT and PT Meter Enclosure Mounts
- (5) See MS-3-21.0 7200/12470V CT and PT Meter Enclosure Pad

**Important:**

Socket shall be wired phase 1-2-3 from left to right and the conductors marked as such. Each conductor phase will be identified at the weather head or padmount, and at the meter base using band-wraps of electrical tape: one band for phase one, two bands for phase two, and three bands for phase three. White tape is suitable for neutral conductors only.

7200/12470V Primary REC Meter Enclosure

MS-8-5.0

Underground Service

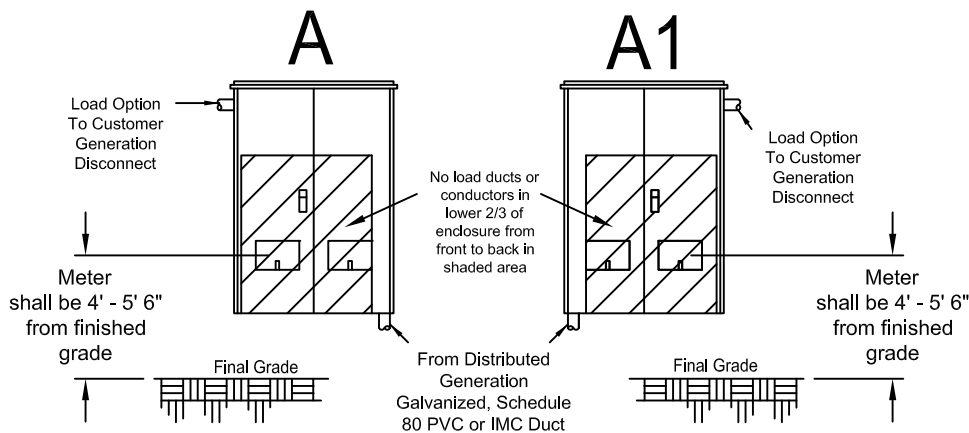

NOTES

- (1) MS-3-2.0 Double-Window Three-Phase Instrument Transformer and Meter Enclosure.
- (2) Must be used when main switch is larger than 200A.
- (3) Use only one of the options.
- (4) Must have 3/4" plywood backing inside enclosure.
- (5) If ducts or conductors cannot be kept out of shaded area due to parallel or large conductors. Drawings B must be used.
- (6) Maximum of 2 runs of 500 kcmil cable in a maximum of 2 ducts.
- (7) Line and load options shall be on different quarter section.
- (8) Must pull neutral for every circuit and cannot undersize by more than one size of the phases conductors. Neutral to be same size as phase conductors.
- (9) Cannot terminate neutral in meter enclosure (must pull neutral thru REC enclosure to another device i.e. additional disconnect or distribution block)
- (10) Metering and instrument cabinets shall not be used to house Customer-owned equipment, such as distribution panels or other equipment, nor used as a junction box/trough for the distribution of circuits.
- (11) Meter shall be 4' - 5' 6" from finished grade.

Important:

Socket shall be wired phase 1-2-3 from left to right and the conductors marked as such. Each conductor phase will be identified at the weather head or padmount, and at the meter base using band-wraps of electrical tape: one band for phase one, two bands for phase two, and three bands for phase three. White tape is suitable for neutral conductors only.

Underground Service

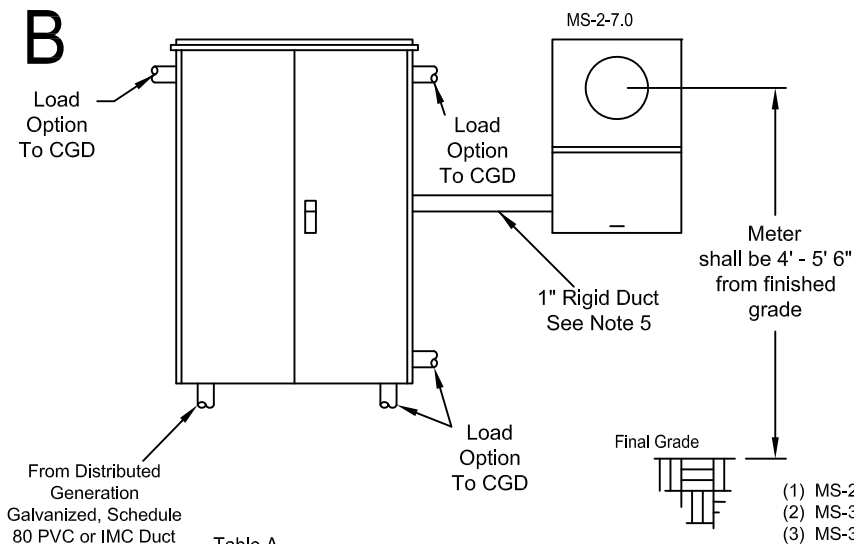

NOTES

- (1) MS-2-7.0 Three-Phase Thirteen-Terminal Socket for CT Meter
- (2) MS-3-3.0 Recording Meter Instrument Transformer Enclosure
- (3) MS-3-4.0 Triplex Meter Enclosure
- (4) If the number of runs or duct size exceed that allowed by Table A, use MS-3-3.0, MS-3-4.0 or MS-3-11.0 enclosure.
- (5) Use only one of the load options.
- (6) Does not necessarily go to transformer. Ducts have to be unbroken.
- (7) All enclosures (drawings A, B and C) shall be securely mounted to building
- (8) Line and load options shall be on different quarter section.
- (9) Customer Generation Disconnect (CGD)
- (10) Cannot terminate neutral in meter enclosure (must pull neutral thru REC enclosure to another device I.E. additional disconnect or distribution block)
- (11) Metering and instrument cabinets shall not be used to house Customer-owned equipment, such as distribution panels or other equipment, nor used as a junction box/trough for the distribution of circuits.
- (12) Meter shall be 4' - 5' 6" from finished grade.

Table A

Allowed Number of Ducts	Maximum Conductors Size
2	750 kcmil
3	500 kcmil
4	Not Allowed
Maximum Four Conductors Per Duct	

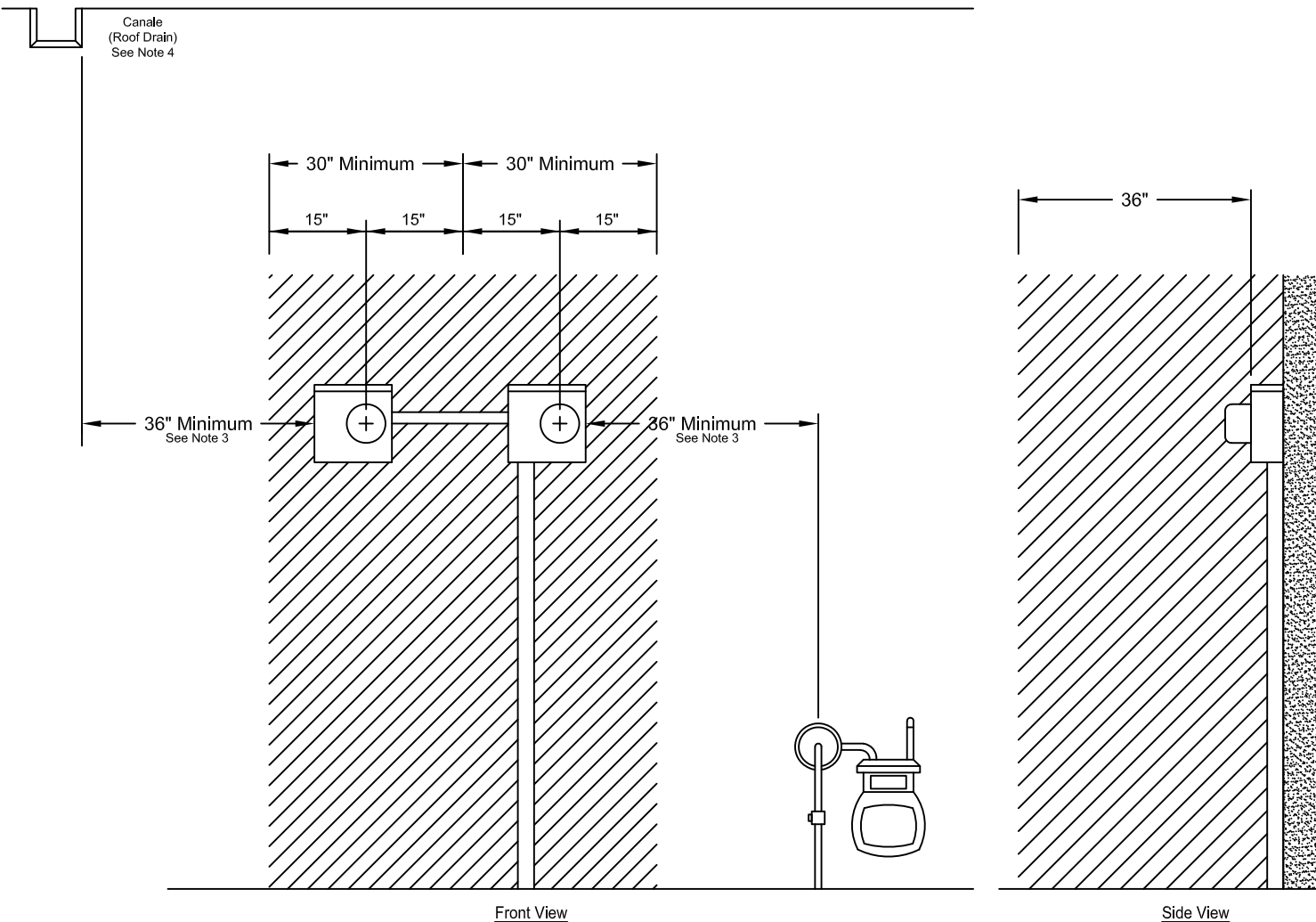

NOTES

- (1) Shaded area is considered working space and shall be kept clear of all obstacles (including landscaping) to permit ready and safe operation and maintenance of the service equipment.
- (2) Electric meter shall be protected with extended curbs or ballards (guard posts) in traffic areas to maintain working space.
- (3) Clearance from meter socket, gas regulator, canales (roof drains) is 36" minimum.
- (4) This drawing is to be used for dimensioning purposes only. Canales (roof drains) are NOT allowed to be installed over electric and gas meters.

REFERENCES

- (1) NEC 110-16 Working Space
- (2) See DS-7-16.10 Guard Post

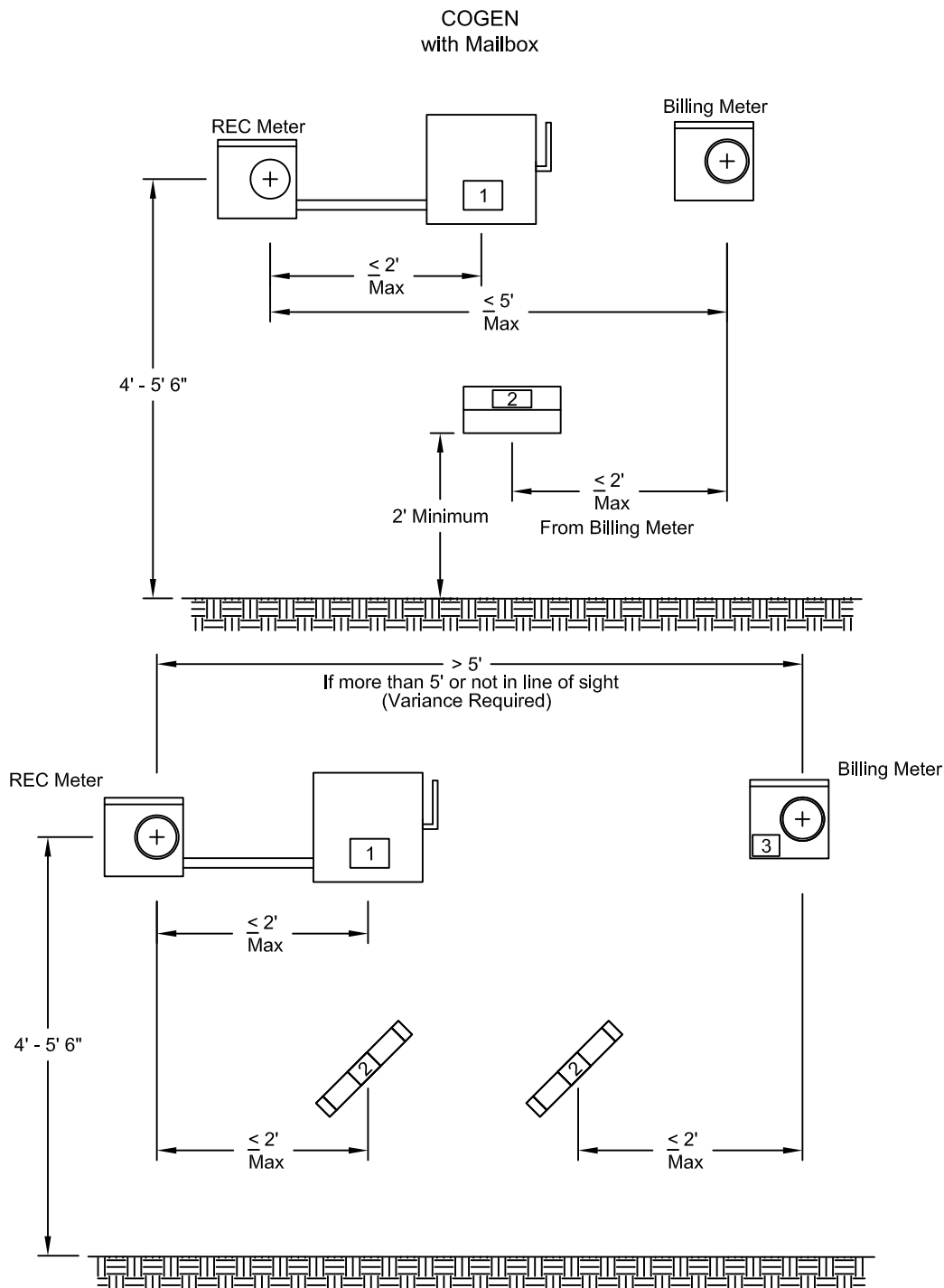

**NOTES**

- (1) Disconnect Label: Red etched placard on switch must identify type of COGEN and contain the language "Generation Disconnect", i. e. "PV Generation Disconnect" or "Energy Storage Disconnect" or "Wind generation Disconnect."
- (2) One-Line Electrical and Site Map: Weatherproof drawings located within 2' of billing meter. See table for approved methods.
- (3) If REC meter is greater than 5' from or not in line of site of the billing meter:
  - A red etched placard on the billing meter that reads "Warning Customer Owned Generation Connected. See drawing for disconnect location."
  - One-line and Site Map located within 2' if both REC and Billing meters.
- (4) To pass meter set inspection, all generator equipment and breakers must be ready in the ON position, and inverter is programmed and ready to operate. PNM cannot access or operated any customer owned equipment except for the utility meter and utility accessible Generation Disconnect.

APPROVED WEATHERPROOF METHODS FOR DRAWINGS:
Etched placard, legible and permanently fixed
Document canister by Agri Supply or equivalent
Mail box



ESS ONLY  
with Tube

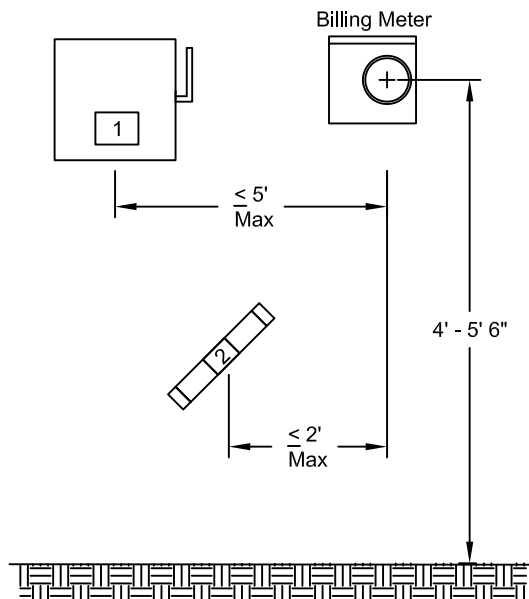

NOTES

- (1) Disconnect Label: Red etched placard on switch must identify type of COGEN and contain the language "Generation Disconnect", i. e. "PV Generation Disconnect" or "Energy Storage Disconnect" or "Wind generation Disconnect."
- (2) One-Line Electrical and Site Diagram: Weatherproof drawings located within 2' of billing meter. See table for approved methods.
- (3) If REC meter is greater than 5' from or not in line of site of the billing meter:
  - A red etched placard on the billing meter that reads "Warning Customer Owned Generation Connected. See drawing for disconnect location."
  - One-line and Site Map located within 2' if both and Billing meters.
- (4) To pass meter set inspection, all generator equipment and breakers must be ready in the ON position, and inverter programmed and ready to operate. PNM cannot access or operated any customer owned equipment except for the meter and utility accessible Generation Disconnect.

APPROVED WEATHERPROOF MEATHODS FOR DRAWINGS:

- (1) Etched placard, legible and permanently fixed.
- (2) Document canister by Agri Supply or equivalent
- (3) Mail box